

ژنراتور : Mecc Alte

موتور دیزل : DEUTZ

Standby		Prime		دیزل ژنراتور
KVA	KW	KVA	KW	
275	-	250	200	



TCD 2013

for power generating sets

90 - 260 kW | 121 - 349 hp at 1500/1800 min⁻¹ | rpm

EU Stage IIIA / US EPA Tier 3

- Watercooled 4 or 6-cylinder inline engines with turbocharging and charge air cooling.
- The powerful DEUTZ Common Rail (DCR[®]) injection system and the electronic engine control (EMR 4) with intelligent link to the drive management ensure optimum engine performance at low fuel consumption.
- Easy, inexpensive installation due to minimum weight and small installation space.



- Air filter and cooling system are fully pre-assembled.

- Low noise emissions due to acoustically optimized components with very smooth running and high durability.
- Wet cylinder liners, long oil change intervals and easy changing of the engine fluids reduce the running costs and increase the availability of the machinery.
- Best cold starting performance even under extreme conditions.
- The TCD 2013 meets the requirements of the EU Stage IIIA and US EPA Tier 3.

Technical data

Engine type		TCD 2013 L4 2V	TCD 2013 L6 2V	TCD 2013 L6 4V
No. of cylinders		4	6	6
Bore/stroke	mm in	108/130 4.3/5.1	108/130 4.3/5.1	108/130 4.3/5.1
Displacement	l cu in	4.8 293	7.2 439	7.2 439
Weight with cooling system and air filter	kg lb	660 1455	945 2083	955 2105
Governing standard ¹⁾		G2	G3	G3

50 Hz / 1500 min⁻¹

Power		TCD 2013 L4 2V	TCD 2013 L6 2V	TCD 2013 L6 4V
Continuous Power (COP) ²⁾	kW hp	90 121	136 182	226 303
Prime Power (PRP) ³⁾	kW hp	95 128	144 192	238 319
Limited Time Power (LTP) ⁴⁾	kW hp	100 135	151 202	251 336
Fan power consumption	kW hp	2.6 3	5.0 7	9.2 12
Typical Generator Output COP ⁵⁾	kVA	99	151	249
Typical Generator Output PRP ⁵⁾	kVA	104	159	263
Typical Generator Output LTP ⁵⁾	kVA	110	168	278

60 Hz / 1800 min⁻¹

Power output		TCD 2013 L4 2V	TCD 2013 L6 2V	TCD 2013 L6 4V
Continuous Power (COP) ²⁾	kW hp	103 138	156 209	234 314
Prime Power (PRP) ³⁾	kW hp	109 146	165 221	247 332
Limited Time Power (LTP) ⁴⁾	kW hp	114 153	174 233	260 349
Fan power consumption	kW hp	4.4 6	8.7 12	15.8 21
Typical Generator Output COP ⁵⁾	kWe	89	136	201
Typical Generator Output PRP ⁵⁾	kWe	94	144	213
Typical Generator Output LTP ⁵⁾	kWe	99	152	225

1) According to ISO 8528-5.

2) Continuous Power: No time limitation, plus 10% additional power for governing purpose only.

3) Prime Power: Average power output ≤ 80%, no time limitation, plus 5% additional power for governing purpose only.

4) Limited Time Running Power: For up to 500 h/year, thereof a maximum of 300 h/year continuous running.

5) In consideration of a generator efficiency level of 90 - 92 % and a power factor of 0.8.

50 Hz / 1500 min⁻¹

Fuel Consumption (PRP) ⁶⁾		TCD 2013 L4 2V	TCD 2013 L6 2V	TCD 2013 L6 4V
Fuel consumption 25% load	g/kWh lb/hph	318 0.52	260 0.43	253 0.42
Fuel consumption 50% load	g/kWh lb/hph	284 0.47	249 0.41	235 0.39
Fuel consumption 75% load	g/kWh lb/hph	270 0.44	236 0.39	225 0.37
Fuel consumption 100% load	g/kWh lb/hph	244 0.40	216 0.36	210 0.35

Heat balance & cooling system		TCD 2013 L4 2V	TCD 2013 L6 2V	TCD 2013 L6 4V
Heat dissipation (engine radiator) ²⁾	kW hp	50 67	74 99	133 178
Heat dissipation (CAC) ²⁾	kW hp	19 25	23 31	39 52
Heat dissipation (convection)	kW hp	9 12	14 19	23 31
Cooling air flow	m ³ /h cfm	6480 3814	11500 6769	15480 9111

Inlet & exhaust data		TCD 2013 L4 2V	TCD 2013 L6 2V	TCD 2013 L6 4V
max. intake depression	mbar psi	10 0.15	10 0.15	10 0.15
Combustion air volume	m ³ /h cfm	450 265	600 353	756 445
max. exhaust gas temperature	°C °F	530 986	485 905	515 959
Exhaust gas flow	m ³ /h cfm	1261 742	1587 934	2079 1224

60 Hz / 1800 min⁻¹

Fuel Consumption (PRP) ⁶⁾		TCD 2013 L4 2V	TCD 2013 L6 2V	TCD 2013 L6 4V
Fuel consumption 25% load	g/kWh lb/hph	318 0.52	288 0.47	255 0.42
Fuel consumption 50% load	g/kWh lb/hph	282 0.46	260 0.43	234 0.38
Fuel consumption 75% load	g/kWh lb/hph	263 0.43	243 0.40	245 0.40
Fuel consumption 100% load	g/kWh lb/hph	233 0.38	223 0.37	218 0.36

Heat balance & cooling system		TCD 2013 L4 2V	TCD 2013 L6 2V	TCD 2013 L6 4V
Heat dissipation (engine radiator) ⁷⁾	kW hp	57 76	73 98	141 189
Heat dissipation (CAC) ⁷⁾	kW hp	20 27	26 35	46 62
Heat dissipation (convection)	kW hp	10 13	16 21	24 32
Cooling air flow	m ³ /h cfm	7560 4450	13320 7840	18720 11018

Inlet & exhaust data		TCD 2013 L4 2V	TCD 2013 L6 2V	TCD 2013 L6 4V
max. intake depression	mbar psi	20 0.29	20 0.29	20 0.29
Combustion air volume	m ³ /h cfm	492 290	660 388	858 505
max. exhaust gas temperature	°C °F	540 1004	511 952	485 905
Exhaust gas flow	m ³ /h cfm	1396 822	1806 1063	2270 1336

6) Refers to diesel with a density of 0.835 kg/dm³ at 15°C | 6.96 lb/US gallon at 60°F.

7) The heat quantities are valid for the dimensioning of the cooling system.

The data on this data sheet are for information purposes only and are not binding values. The data in the quotation is definitive.

Dimensions

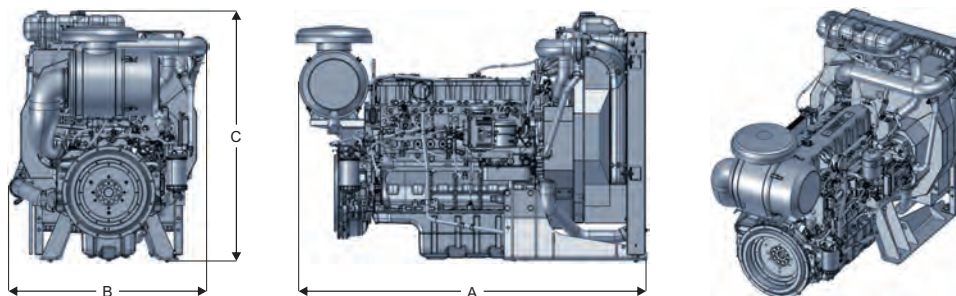

		A	B	C
TCD 2013 L4 2V	mm	1589	880	1247
TCD 2013 L6 2V	mm	1909	879	1263
TCD 2013 L6 4V	mm	1865	1046	1322

Note: The engine dimensions and weights vary depending on the scope of delivery.

For more information please contact the DEUTZ AG Köln or the responsible sales partner.





GENERATOR TYPE ECO 38-1LN/4

Document : DS073A/1

issue 004 date 28/10/2013

Electrical Characteristics										
Frequency	Hz	50				60				
Voltage (series star)	V	380	400	415	440	415	440	460	480	
Rated power class H	kVA	250	250	250	230	290	300	300	300	
	kW	200	200	200	184	232	240	240	240	
Rated power class F	kVA	230	230	230	215	270	280	280	280	
	kW	184	184	184	172	216	224	224	224	
Regulation with DSR		±1 % with any power factor and speed variations between -5% +30%								
Insulation class		H								
Execution		Brushless								
Stator winding		12 ends								
Rotor		with damping cage								
Efficiencies class H	4/4	%	93,3	93,4	93,1	92,9	93,8	94,3	94,4	94,5
(see graph. for details)	3/4	%	93,4	93,7	93,6	93,3	94,3	94,5	94,7	94,9
	2/4	%	92,3	92,4	92,4	92,2	93,4	93,5	93,6	93,7
	1/4	%	90,1	89,9	89,7	89,5	90,6	90,6	90,6	90,4
Reactances (f. l.cl. F)	Xd	%	229,4	207	192,3	157,4	267,7	246,3	225,4	207
	Xd'	%	15,5	14,0	13,0	10,6	18,1	16,7	15,2	14,0
	Xd''	%	8,0	7,2	6,7	5,5	9,3	8,6	7,8	7,2
	Xq	%	129,6	117	108,7	89,0	151,3	139,2	127,4	117
	Xq'	%	129,6	117	108,7	89,0	151,3	139,2	127,4	117
	Xq''	%	24,4	22	20,4	16,7	28,5	26,2	24,0	22
	X ₂	%	17,7	16,0	14,9	12,2	20,7	19,0	17,4	16,0
	X ₀	%	2,7	2,4	2,2	1,8	3,1	2,9	2,6	2,4
Short Circuit Ratio	Kcc		0,41	0,44	0,68	1,11	0,32	0,38	0,41	0,44
Time Constants	Td'	sec.	0,085							
	Td''	sec.	0,013							
	Tdo'	sec.	1,30							
	Tα	sec.	0,017							
Short Circuit Current Capacity		%	>300				>350			
Excitation at no load	Amp.		0,6	0,71	0,8	0,95	0,4	0,5	0,58	0,7
Excitation at full load	Amp.		2,7	2,8	3	3,2	2,4	2,6	2,7	2,8
Overload (long-term)		%	1 hour in a 6 hours period 110% rated load							
Overload per 20 sec.		%	300							
Stator Winding Resistance (20°C)		Ω	0,0065							
Rotor Winding Resistance (20°C)		Ω	4,887							
Exciter Resistance (20 °C)		Ω	Rotor : 0,685				Stator : 15,28			
Heat dissipation at f.l.cl.H	W		14362	14133	14823	14062	15335	14507	14237	13968
Telephone Interference			THF < 2%				TIF < 40			
Radio interference			EN61000-6-3, EN61000-6-2. For others standards apply to factory							
Waveform Distors.(THD) at f. load	LL/LN %		2 / 2,1							
Waveform Distors.(THD) at no load	LL/LN %		2,9 / 3,1							
Mechanical characteristics										
Protection			IP 21 (other protection on request)							
DE bearing			6318.2RS							
NDE bearing			6314.2RS							
Weight of wound stator assembly	kg		231							
Weight of wound rotor assembly	kg		147,5							
Weight of complete generator	kg		680							
Maximun overspeed	rpm		2250							
Unbalanced magnetic pull at f.l.cl.F	kN/mm		5,1							
Cooling air requirement	m ³ /min		32				39			
Inertia Constant (H)	sec.		0,116				0,139			
Noise level at 1m/7m	dB(A)		82 / 69				86 / 73			

All technical data are to be considered as a reference and they can be modified without any notice

This document is a propriety of Mecc Alte S.p.a..All rights reserved.



GENERATOR TYPE ECO 38-1LN/4

Document : DS073A/2

issue 004 date : 28/10/2013

50 Hz

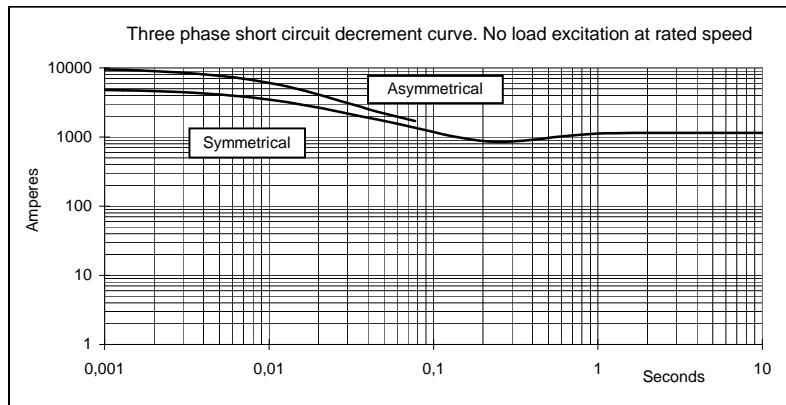
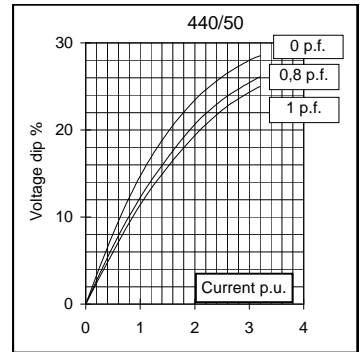
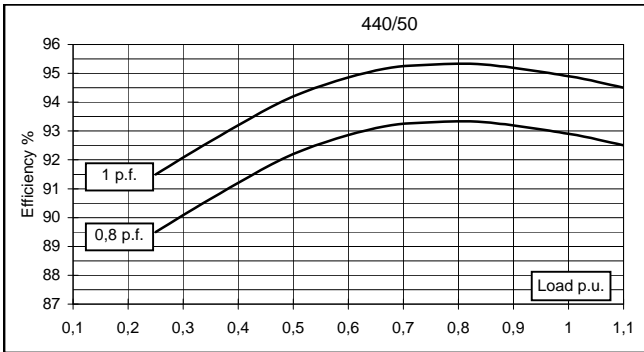
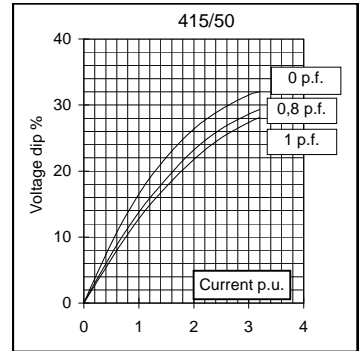
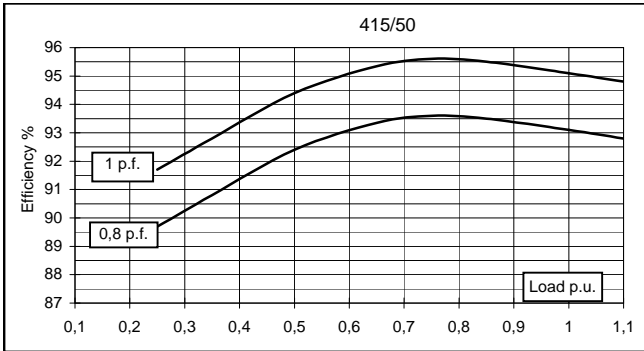
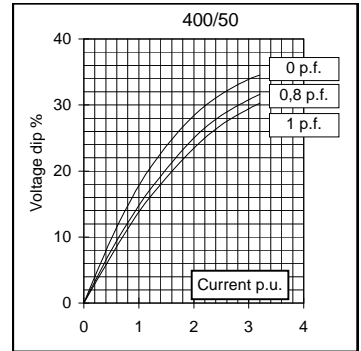
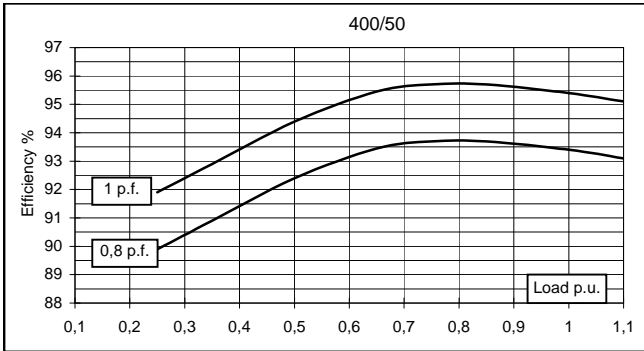
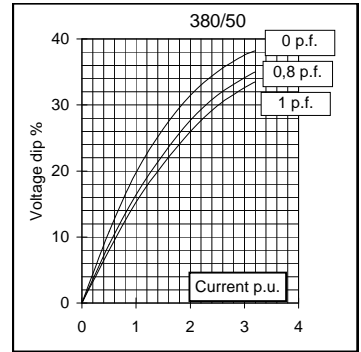
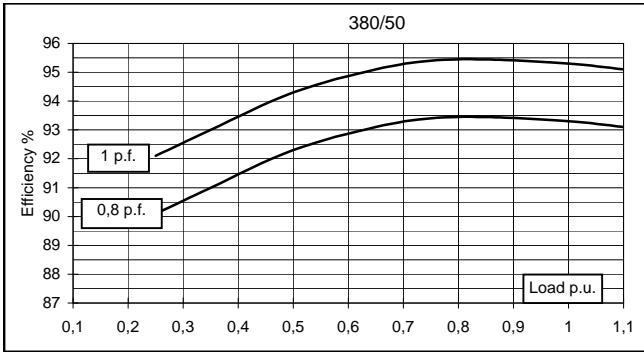



GENERATOR TYPE ECO 38-1LN/4

Document : DS073A/3
issue 004 date : 28/10/2013

60 Hz

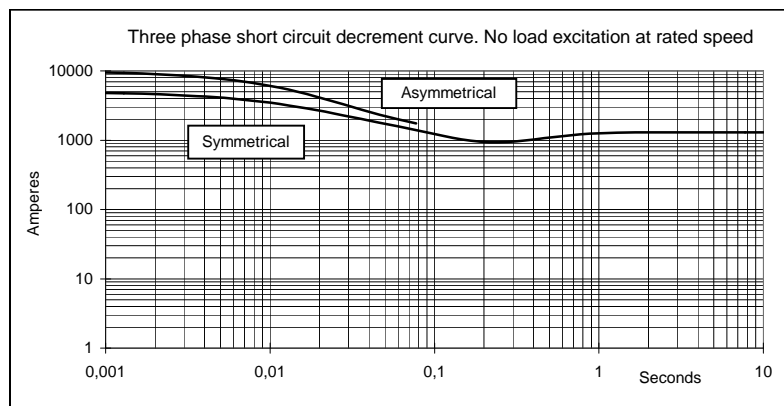
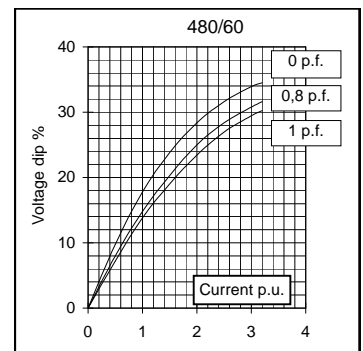
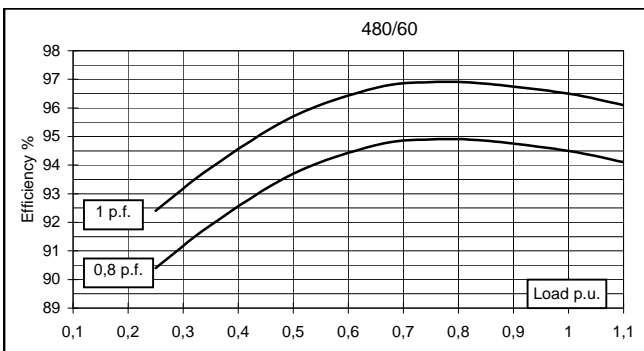
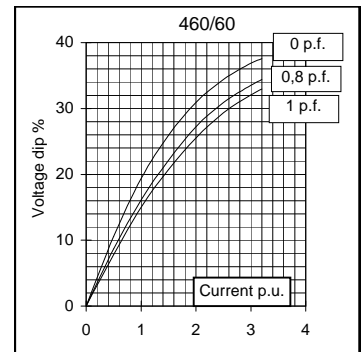
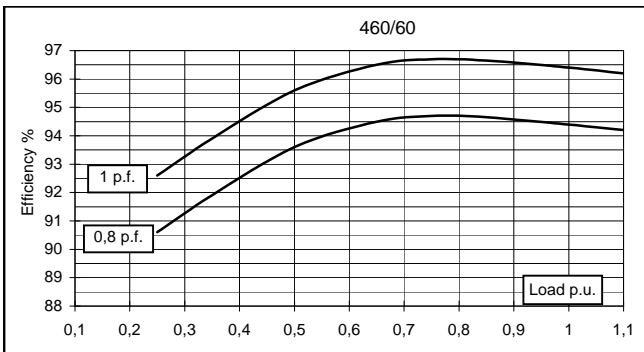
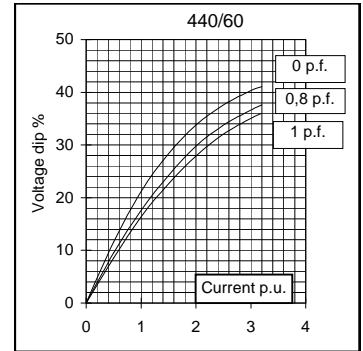
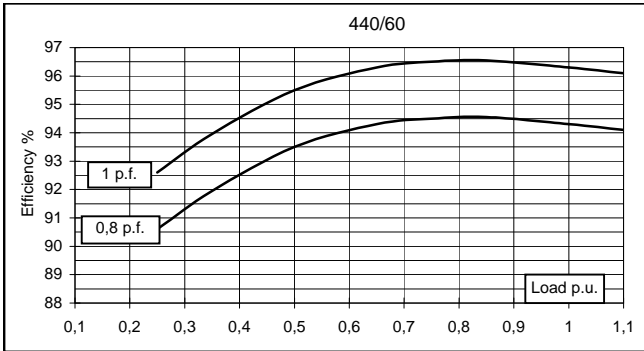
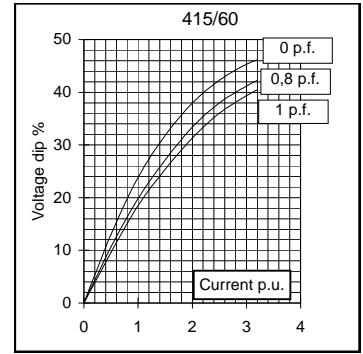
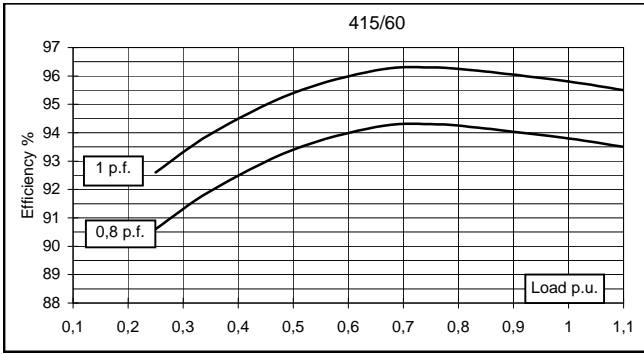

TWO BEARING MOMENTS OF INERTIA

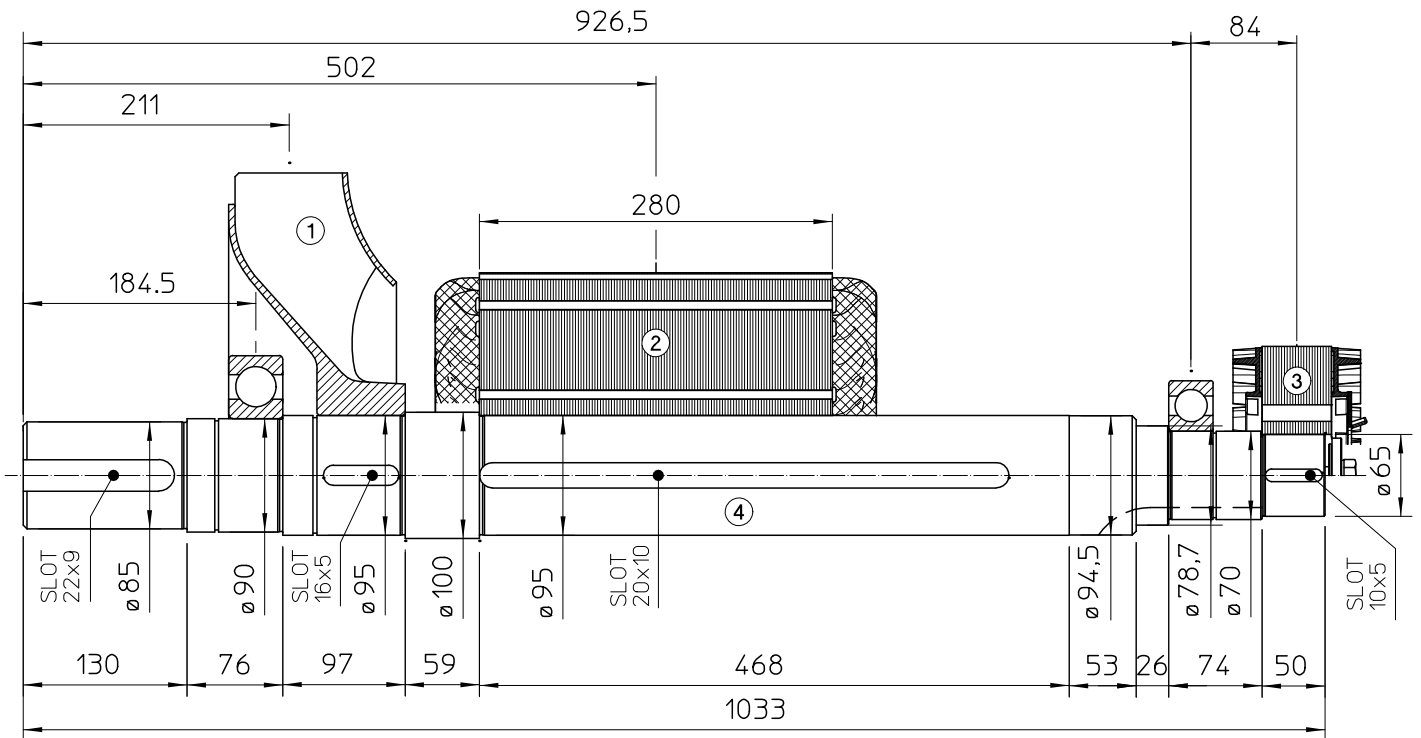

TWO BEARING DIMENSIONS

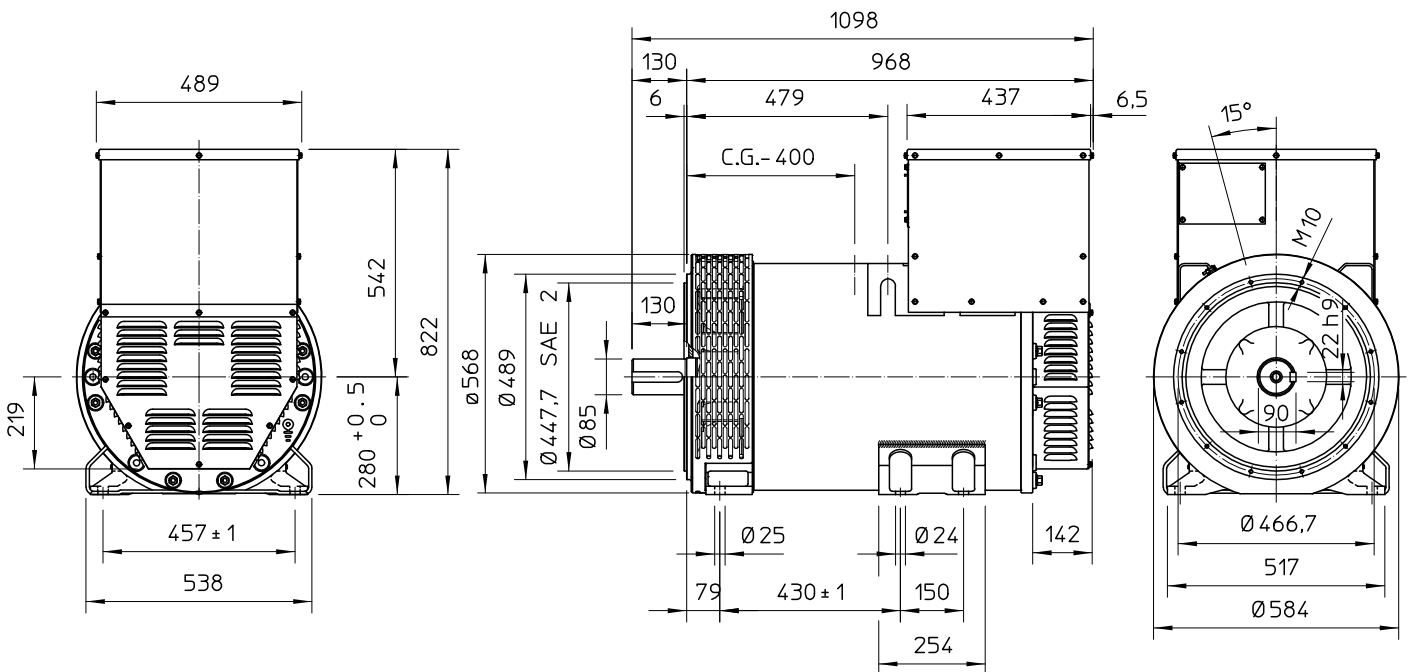

SINGLE BEARING MOMENTS OF INERTIA

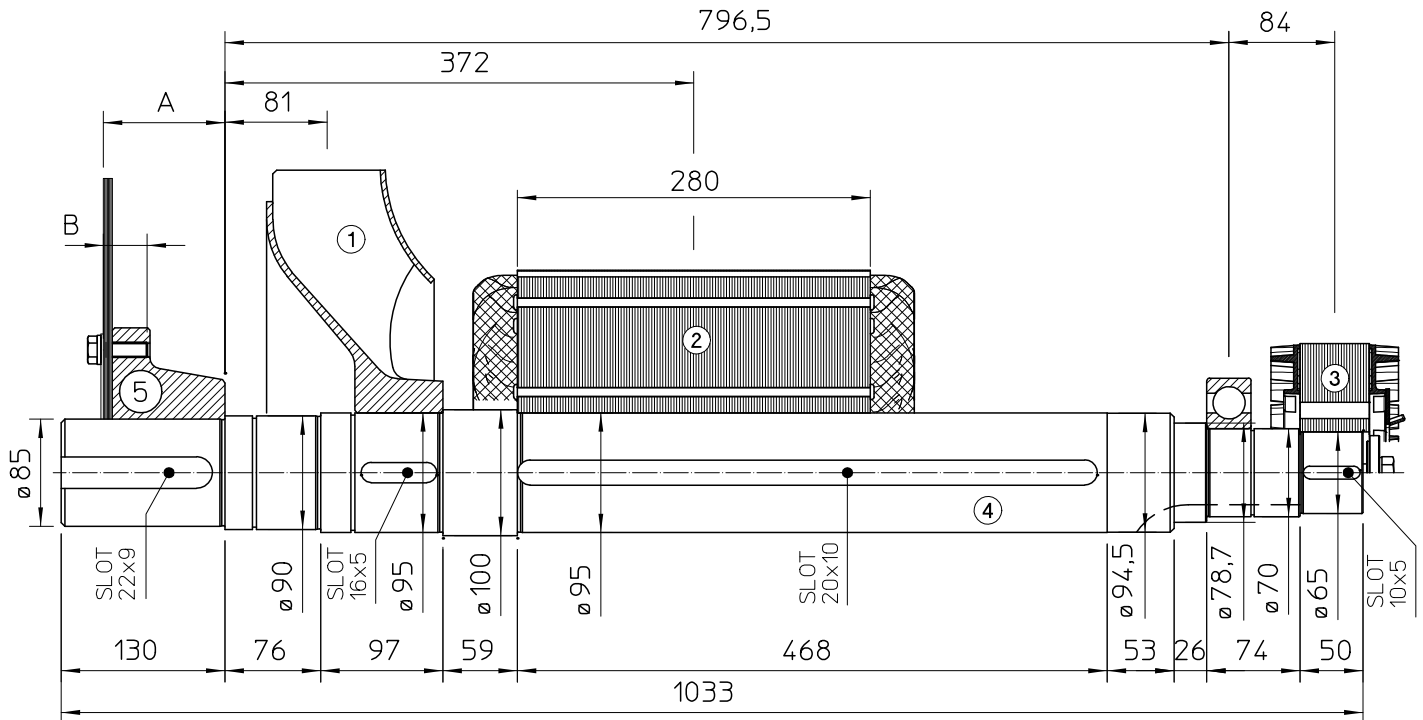

POS.	COMPONENT	WEIGHT (kg)	J (kgm ²)
1	FAN	6.1	0.1887
2	MAIN ROTOR	147.5	2.0195
3	EX. ROTOR	14.5	0.0874
4	SHAFT	49.9	0.0525
TOTAL		218	2.3481

SAE N°	5		SHAFTS COUPLING FLEX PLATE	
	A	B	WEIGHT kg	J kgm ²
11.5	110.4	41.1	20.5	0.174
14	96.4	34.7	23.5	0.275

SINGLE BEARING DIMENSIONS

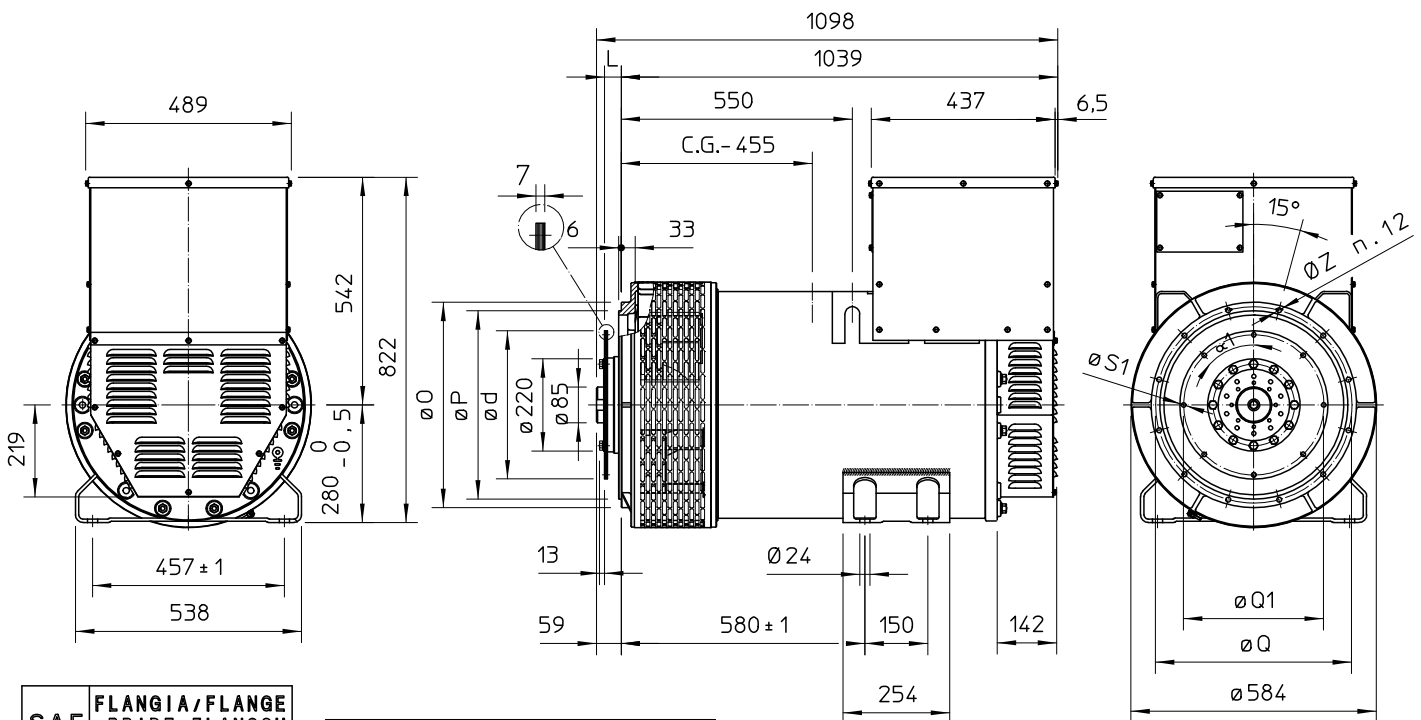

SAE N.	FLANGIA/FLANGE BRIDE/FLANSCH		
	O	P	Q
3	451	409,6	428,6
2	489	447,7	466,7
1	552	511,2	530,2
1/2	648	584,2	619,1

SAE N.	GIUNTI A DISCHI DISC COUPLING DISQUE DE MONOPALIER SCHEIBENKUPPLUNG					
	L	d	Q1	n _{fori}	S1	α1
11 1/2	39,6	352,42	333,37	8	11	45°
14	25,4	466,72	438,15	8	14	45°

C.G.= GRAVITY CENTER