

WARMAN®
Centrifugal Slurry Pumps

Excellent
Minerals
Solutions
WEIR
MINERALS

Slurry Pump Handbook - 2009

Fifth Edition
Electronic Version
February 2009

Foreword

This publication is intended primarily to provide a basic understanding of slurry pumping and slurry pumps for users and specifiers of slurry pumps, and serve as a concise reference source for experienced slurry pumping practitioners. It is impossible to cover all facets of the subject in a concise handbook like this. However, the worldwide resources of Warman are always available to assist in answering your slurry pumping questions.

DISCLAIMER

As in most complex technical disciplines, no single handbook can fully provide data on all aspects and applications. Experience and skill in the interpretation of application data and in the use of empirical or subjective factors are necessary for the correct design and engineering of many slurry pump applications. While precaution has been taken to ensure the accuracy of the contents of this handbook, no responsibility or liability (whether for loss, damage, death or injury or otherwise) can be accepted by Warman for any misinterpretation or misapplication of any kind of the empirical and other formula and data described, nor, apart from any warranties or conditions which might be implied by the Trade Practices Act, can any liability be accepted for any errors or omissions in the text.

TABLE OF ILLUSTRATIONS

Figure 1-1 — Impeller Vane Profiles	1-2	Figure 4-3 Type L Pump	4-3
Figure 1-2 — Impeller/Casing Flow Patterns	1-3	Figure 4-4 Type AHU Pump	4-4
Figure 1-3 — Standard and Non-Standard Impeller Types	1-4	Figure 4-5 Type D Pump	4-5
Figure 1-4 — Reduced Diameter Impellers	1-5	Figure 4-6 Type TC/C Pump	4-6
Figure 1-5 — Pump Casing Shapes	1-5	Figure 4-7 Type SP Pump	4-7
Figure 2-1 Three Main Modes of Abrasive Wear	2-1	Figure 4-8 Type SPR Pump	4-8
Figure 2-2 Three Main Modes of Erosive Wear	2-2	Figure 4-9 Type HDSP Series AHU/C Pump	4-9
Figure 2-3 Performance of Centrifugal Pumps on Slurry	2-5	Figure 4-10 Type V-TC Pumps	4-10
Figure 2-4 Typical Pump Performance Test Graph On Water	2-7	Figure 6-1 Typical H_f Curve For Category 'A' Slurries	6-3
Figure 2-5 Typical Pump Performance Graph	2-8	Figure 6-2 Warman Pipe Friction Chart	6-6
Figure 2-6 Typical System Resistance Curve	2-10	Figure 6-3 Pipe Diameter	6-7
Figure 2-7 Typical Duty Point Curve	2-10	Figure 7-1 Total Dynamic Head With Positive Intake Head	7-5
Figure 2-8 Typical Graph Showing Pump Speed Variations	2-10	Figure 7-2 Total Dynamic Head with Negative Intake Head	7-6
Figure 2-9 Typical Graph Showing System Variations	2-11	Figure 7-3 Equivalent Lengths of Pipe Fittings and Valves	7-7
Figure 2-10a Centrifugal (or Dynamic) Seal Arrangements	2-12	Figure 7-4 Head Losses at Inlet, Contraction and Enlargement	7-8
Figure 2-10b Typical Centrifugal Seal Performance Curve	2-12	Figure 7-5 Differential Column Head Loss	7-9
Figure 2-11 Gland Seal Arrangement	2-13	Figure 8-1 Durand's Limiting Settling Velocity Parameter(For Particles of Closely Graded Sizing)	8-3
Figure 2-12 Typical Mechanical Slurry Seal	2-14	Figure 8-2 Modified Durand's Limiting Settling Velocity Parameter(For Particles of Widely Graded Sizing)	8-4
Figure 2-13 Typical Pump Sump And Natural Flow Control Principle	2-16	Figure 9-1A $NPSH_a$ for Positive Suction Conditions	9-3
Figure 2-14 Typical Pump Sump Arrangement for Aerate/Frothy Slurries	2-17	Figure 9-1B $NPSH_a$ for Negative Suction Conditions	9-4
Figure 2-15 Pump Discharge Orientation To Minimize Air Locking	2-18	Figure 9-1C $NPSH_a$ Pumping from a Closed Pressurized Vessel	9-5
Figure 2-16 Typical Cyclone Arrangement	2-19	Figure 9-1D $NPSH_a$ Pumping from a Closed Vessel Under Vacuum	9-6
Figure 3-1 Typical Warman Preliminary Selection Chart	3-3	Figure 9-2 Approximate Barometric Pressures	9-7
Figure 3-2 Typical Conical Enlargement	3-4	Figure 9-3 Absolute Vapor Pressure of Pure Water	9-7
Figure 3-3 Typical Pump Application	3-10	Figure 10-1 Single Pump	10-2
Figure 3-4 Warman Pump Performance Curve	3-11	Table 10-2 Calculation of Power and Head for Multi-Stage Sets	10-3
Figure 4-1 Type AH Pump	4-1	Figure 10-3 Two-Stage Pump Unit	10-3
Figure 4-2 Type GP Pump	4-2	Figure 10-4 Four-Stage Pump Unit	10-4

Contents

Section 1 - Slurry Pump Principles

Introduction	1-1
Definition of a Slurry	
Characteristics of a Slurry	
What is a Slurry Pump?	
Components of a Slurry Pump	1-2
Impellers	
Pumping Coarse Coal	
Pumping Fibrous Material	
High Intake Head	
Reduced Diameter Impellers	
Reduced Eye Impellers	
Casings	
Range of Applications of a Slurry Pump	1-6
Concepts of Material Selection	1-6
Elastomers	
Natural rubber	
Polyurethane	
Synthetic Elastomers:	
Wear/Erosion Resistant Cast Alloys	

Section 2 - Defining your Application & Constraints

Properties of a Slurry	2-1
Abrasion	
Erosion	
Solids Concentration	
Effects On Material Selection	
Volume/Flow Rate	2-4
Pipeline Length	2-6
Static Head Required	2-6
Pipe Size	2-6
Pump Performance Graphs	2-9
System Resistance Curves	2-9

Other Design Constraints	2-11
Shaft Sealing	
Centrifugal (or Dynamic) Seal	
Gland Seal	
Mechanical Seal	
Pump Sumps	
Air Locks	
Head Loss At Exit Into Pressure-Fed Equipment	
Pump Bursting Hazard	

Section 3 - Selecting the Appropriate Pump

Determine The Flow Rate	3-1
Determine The Static Head	3-1
Determine The Pump Head and Efficiency Corrections	3-1
Determine The Pipe Diameter	3-1
Calculate The Friction Head Loss	3-1
Calculate The Total Dynamic Head	3-1
Select Pump Type and Materials	3-2
Pump Selection	3-2
Determine The Pump Speed	3-2
Calculate The Required Power	3-2
Additional Design Considerations	3-2
NPSH	
Casing Pressure	
Froth Pumping	
Conical Enlargements	
Pump Feed Sumps	
Shaft Sealing	
Multi-Staging	
Drive Selection	
Typical Pump Calculation	3-6
Quantity Pumped	
Size Of Pipeline	
Friction Head H_f For The Pipeline	
Loss In Discharge Pipe Enlargement	

Loss Of Head At Entrance To Suction Pipe
Equivalent Water Total Dynamic Head
Pump Selection

Section 4 - Pump Types

Introduction	4-1
Horizontal Pumps-Lined	4-1
Type AH	
Type GP	
Type L	
Type AHP	
Type HRM	
Type W	
Type AHF/LF/MF	
Horizontal Pumps-Unlined	4-4
Type AHU	
Type D	
Type G	
Type GH	
Type TC/C	
Type AHUC	
Vertical Pumps	4-6
Type SP/SPR	
Type HDSP Series AHU/C	
Type V-TC	

Section 5 - Materials

Introduction	5-1
Material Types and Data Descriptions	5-2

Section 6 - Friction Data

Introduction	6-1
Homogeneous Slurries	6-1
Heterogeneous Slurries	6-1
Estimation of Friction Head Losses For Clear Water	6-4

Section 7 - Total Dynamic Head

Introduction / Abstract 7-1

Total Discharge Head, H_d

Total Suction Head, H_s

Relationships Between Head, Specific Gravity & Pressure, or Vacuum 7-2

Total Dynamic Head 7-2

Total Dynamic Head: With Positive (+ve) Suction Head

Total Dynamic Head: With Negative (-ve) Suction Head

Estimation of Total Dynamic Head

Total Discharge Head: H_d

Total Suction Head: H_s

Separate Estimates of Suction Head and Discharge Head 7-3

Pipeline Friction Head Loss, H_f

Inlet Head Loss, H_i ; Exit Velocity Head Loss, H_{ve} .

Head Losses due to Contractions and Enlargements

Several Additional Causes of Effects on H_{fs} or H_{fd}

Differential Column Head Loss

Section 8 - Velocity

Limiting Settling Velocity 8-1

Determination of Limiting Settling Velocity 8-1

Effect of Pipe Diameter on Limiting Velocity 8-2

Section 9 - Net Positive Suction Head

General Notes 9-1

NPSH Required (NPSH_r) 9-1

NPSH Available (NPSH_a) 9-2

Formula for NPSH_a 9-2

Section 10 - Series Pumping

Introduction 10-1

Single Pump 10-1

Two-Stage Pump Unit 10-1

Four-Stage Pump Unit 10-2

Section 1 - Slurry Pump Principles

Introduction

Definition of a Slurry

A slurry can be a mixture of virtually any liquid combined with some solid particles. The combination of the type, size, shape and quantity of the particles together with the nature of the transporting liquid determines the exact characteristics and flow properties of the slurry.

Characteristics of a Slurry

Slurries can be broadly divided into the two general groups of non-settling or settling types.

Non-settling slurries entail very fine particles which can form stable homogeneous mixtures exhibiting increased apparent viscosity. These slurries usually have low wearing properties but require very careful consideration when selecting the correct pump and drive as they often do not behave in the manner of a normal liquid. When fine solids are present in the slurry in sufficient quantity to cause this change in behavior away from a normal liquid, they are referred to as non-Newtonian.

Settling slurries are formed by coarser particles and tend to form an unstable mixture. Therefore, particular attention must be given to flow and power calculations. These coarser particles tend to have higher wearing properties and form the majority of slurry applications. This type of slurry is also referred to as heterogeneous.

What is a Slurry Pump?

There are a number of different pump types used in the pumping of slurries. Positive displacement and special effect types such as venturi eductors are used but by far the most common type of slurry pump is the centrifugal pump. The centrifugal slurry pump utilizes the centrifugal force generated by a rotating impeller to impart kinetic energy to the slurry in the same manner as clear liquid type centrifugal pumps.

However, this is where the similarities end.

The selection process for centrifugal slurry pumps needs to include consideration for impeller size and design for solids passage, appropriate shaft seal possibilities and optimum, long life material selections. These basics need to be considered by the application engineer who will select the liquid end parts to withstand

wear caused by the abrasive, erosive and/or corrosive attack on the wetted materials. Refer to Section 5 for further details on these special materials. Additionally, we will contemplate other important conditions of service in later sections of this book.

To achieve lower operating speeds, slurry pumps are also generally larger in size than comparable clear liquid pumps in order to reduce velocity thereby minimizing the rate of wear. Bearings and shafts also need to be much more rugged and rigid. Refer to Section 4 for further details of the various Warman types.

Components of a Slurry Pump

Impellers

The impeller is the main rotating component which normally has vanes to impart and direct the centrifugal force to the liquid. Usually, slurry pump impellers have a plain or a Francis type vane (see Figure 1-1).

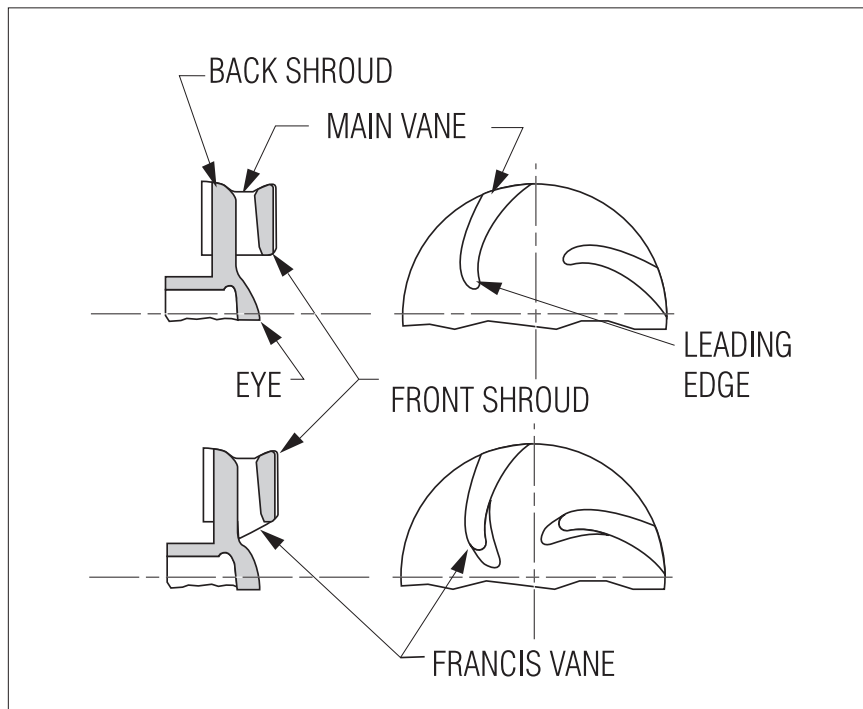

Figure 1-1 — Impeller Vane Profiles

The plain vane has a leading edge square to the back shroud, whereas the Francis vane has a leading edge projecting into the impeller eye.

Some advantages of the Francis vane profile are the higher efficiency, improved suction performance and slightly better wear life in certain types of slurry because the incidence angle to the fluid is more effective.

The plain vane type impeller exhibits better wear life characteristics in very coarse slurry applications or where the mold design precludes the Francis type where an elastomer impeller is required.

The number of impeller vanes usually varies between three and six depending on the size of the particles in the slurry.

Slurry impellers are more commonly of the closed type as illustrated (with a front shroud) but semi-open type impellers (without a front shroud) are sometimes used for special applications.

Impellers are generally closed because of higher efficiencies and are less prone to wear in the front liner region. Semi-open impellers are more common in smaller pumps, where particle blockage may be a problem, or where the shear provided by an open impeller is an aid to pumping froth.

Another feature of slurry pump impellers is the pump out or expelling vanes on the back and front shrouds. These perform the dual function of reducing pressure (thus inhibiting recirculating flow back to the impeller eye and reducing stuffing box pressure) and keeping solids out of the gaps between the casing and impeller by centrifugal action.

The impeller design is crucial as it influences flow patterns and, ultimately, wear rates throughout the pump. The influence of design on wear is illustrated in Figure 1-2.

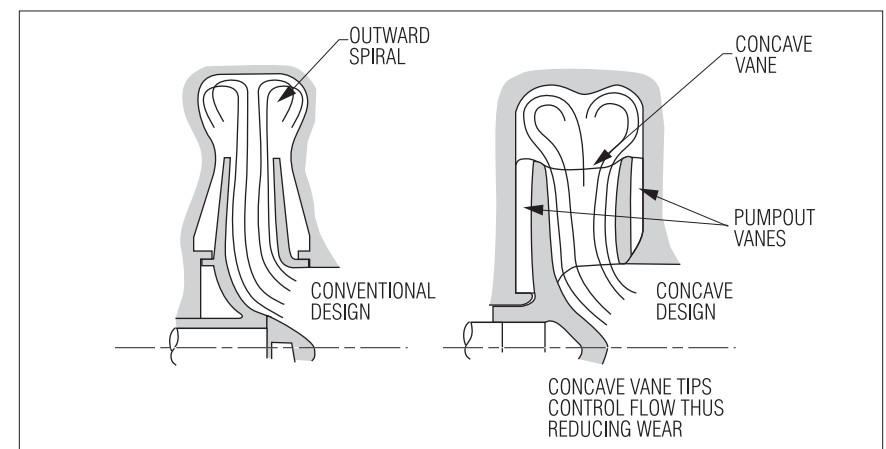

Figure 1-2 — Impeller/Casing Flow Patterns

The wide range of Warman standard impellers cover most slurry pumping duties but special non-standard designs are also available.

Some examples of standard and non-standard impellers are shown in Figure 1-3.

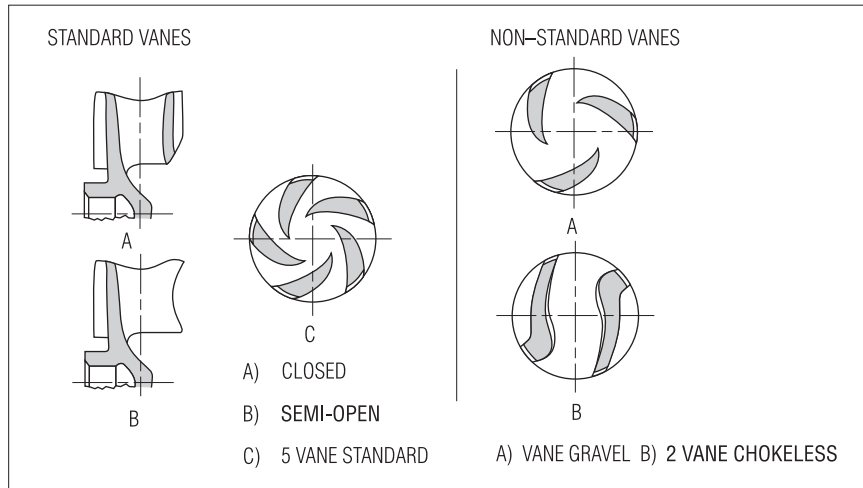

Figure 1-3 — Standard and Non-Standard Impeller Types

Some typical examples of the need for non-standard impellers are:

Pumping Coarse Coal

Large particles may cause blockages with a standard 5 vane closed impeller. A special large particle 4 vane impeller may be required.

Pumping Fibrous Material

Long fibers may get caught around the vane entrance of standard impellers. A special chokeless impeller can be used for these duties.

High Intake Head

Where the intake head exceeds the capability of a centrifugal seal, a differential impeller may be required as illustrated in Figure 1-4.

Reduced Diameter Impellers

In some special cases, reduced diameter impellers are required but are generally avoided as impeller wear is higher than with full diameter impellers with their inherently lower RPM as illustrated in Figure 1-4.

Reduced Eye Impellers

In some extremely high wearing applications such as mill discharge, a special impeller with a reduced eye can prolong impeller wear life.

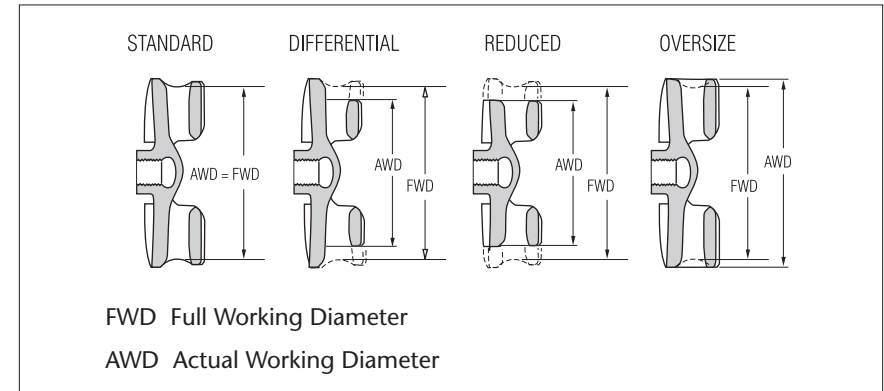

Figure 1-4 — Reduced Diameter Impellers

Casings

Most slurry pump casings are “slower” than water pumps, primarily to reduce wear through lower internal velocities.

The casing shape is generally of a semi-volute or annular geometry, with large clearance at the cutwater. These differences are illustrated in Figure 1-5.

Efficiencies of the more open casings are less than that of the volute type, however, they appear to offer the best compromise in wear life.

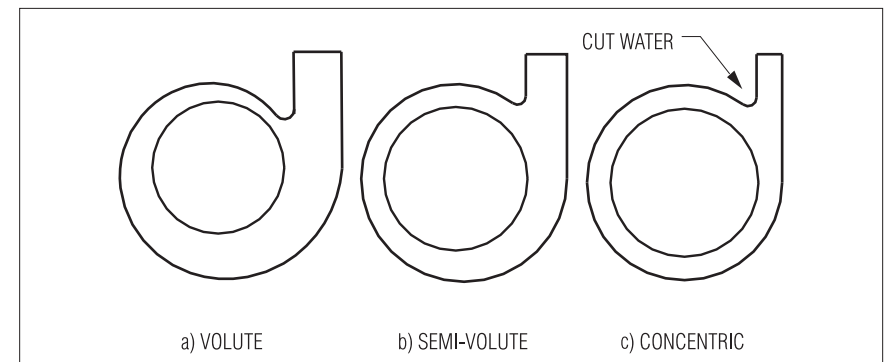

Figure 1-5 — Pump Casing Shapes

Range of Applications of a Slurry Pump

Slurry pumps are used widely throughout the beneficiation section of the mining industry where most plants use wet separation systems. These systems usually move large volumes of slurry through the process.

Slurry pumps are also widely used for the disposal of ash from fossil fuel power plants. Other areas where slurry pumps are used include the manufacture of fertilizers, land reclamation, mining by dredges, and the long distance transportation of coal and minerals.

Increased global focus on the environment and energy consumption will certainly generate much wider uses for slurry pumping in years to come.

Concepts of Material Selection

Selecting the type of materials to be used for slurry pumping applications is not a precise procedure. The procedure must account for all of the variable characteristics of the particular slurry and take into account the constraints imposed by the following:

- type of pump,
- pump speed, and
- options within the range of the models available.

The basic data required to make a selection of the type of material is:

- the particle sizing of the solids to be pumped,
- the shape and hardness of these solids, and
- the corrosive properties of the “liquid” transport component of the slurry to be pumped.

The material selection for the pump liners and impellers is made from two basic types of materials:

- elastomers, and
- wear/erosion resistant cast alloys.

Elastomers

The criteria for selection of the three more commonly used elastomers are:

Natural rubber

- Excellent erosion resistance for liners (against solids up to 1/2 inch size), but limited to particles of 1/4 inch size for impellers.
- May not be suitable for very sharp edged solids.
- May be damaged by oversized solids or tramp.

- Impeller peripheral speed should be less than 5400 ft/min. to avoid the thermal breakdown of the liner adjacent to the outer edge of the impeller. (Special formulations are available to allow speeds up to 5900 ft/min. in certain cases).
- Unsuitable for oils, solvents or strong acids.
- Unsuitable for temperature in excess of 170° F.

Polyurethane

- Used for pump side liners where the peripheral speed of the impeller is higher than 5400 ft/min. (and precluding the use of standard rubber) and used for impellers where occasional tramp may damage a rubber impeller.
- Erosion resistance is greater where erosion is of a sliding bed type rather than one of directional impact, (see Figure 2-2).
- Has less erosion resistance to coarse sharp edged particles than natural rubber. Has greater erosion resistance to fine solids than natural rubber in some circumstances.
- Unsuitable for temperatures exceeding 158° F and for concentrated acids and alkalis, ketone, esters, chlorinated and nitro hydrocarbons. As its temperature capability is raised through reformulation, its wear resistance drops appreciably.

Synthetic Elastomers:

Neoprene, Butyl, Hypalon, Viton A and others

These are used in special chemical applications under the following conditions.

- Not as erosion resistant as natural rubber.
- *Have greater chemical resistance than natural rubber or polyurethane.
- *Generally allows higher operating temperature than natural rubber or polyurethane.

**Refer to Warman for chemical resistance and temperature limits of individual synthetic rubbers.*

Wear/Erosion Resistant Cast Alloys

Wear resistant cast alloys are used for slurry pump liners and impellers where conditions are not suited to rubber, such as with coarse or sharp edged particles, or on duties having high impeller peripheral velocities or high operating temperatures.

NOTE: Unlined pumps are generally available only in these types of alloys.

Section 2 - Defining your Application & Constraints

Properties of a Slurry

Abrasion

Abrasive wear occurs when hard particles are forced against and move relative to a solid surface. Figure 2-1 illustrates the 3 major types of abrasion: gouging, high stress grinding and low stress grinding.

In a centrifugal slurry pump, abrasion only occurs in two areas:

- between the rotating impeller and the stationary throatbush, and
- in between the rotating shaft sleeve and the stationary packing.

Abrasion, although used to cover all types of wear, is quite distinct to erosion.

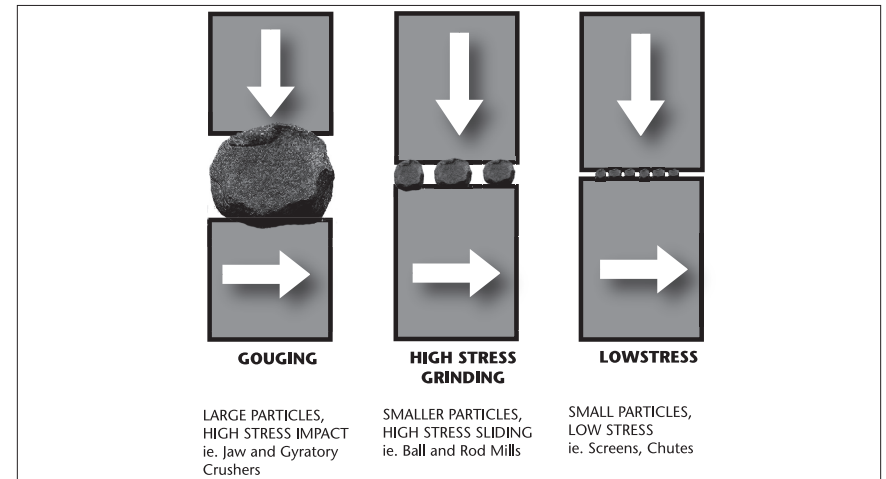

Figure 2-1 Three Main Modes of Abrasive Wear

Erosion

In slurry pump applications, the dominant mode of wear is erosion. Erosion is a form of wear involving the loss of surface material by the action of particles entrained in the fluid.

Erosion involves a transfer of kinetic energy from the particle to the surface,

which does not occur in abrasion.

The transfer of kinetic energy from the particle to the surface results in a high contact stress. While the overall contact pressure at each impact site is small, the specific contact pressure is high because of the irregular shape of the particles.

Three basic types of erosion exist: sliding bed, random impact and directional impact. These are illustrated in Figure 2-2.

Pumping impellers, side liners and volutes wear due to quite different mechanisms as follows:

- Pump impellers are subjected to a combination of direct impingement (on the leading edge of the vane and at the base of the vane where it joins the back shroud), sliding bed wear and low angle impingement (along the vanes and further inside the passage between the shrouds).
- Side liners are mainly subjected to sliding bed wear and some low angle impingement.
- Volutes are subjected to direct impingement on the cutwater and sliding bed erosion around the periphery.

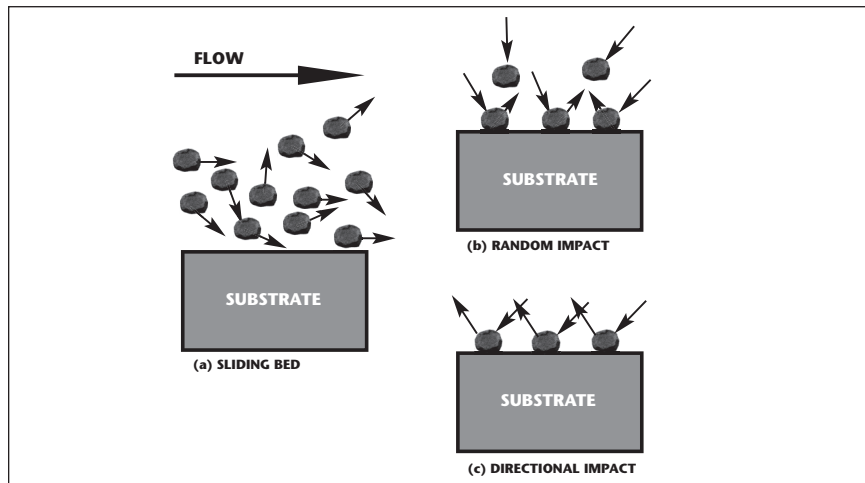

Figure 2-2 Three Main Modes of Erosive Wear

Corrosion

There are many different types of corrosion, some of which are: uniform; galvanic; crevice; pitting; intergranular; selective leaching; stress and erosion/corrosion. The latter is the most important in slurry applications because the two effects (erosion and corrosion) work together and are often difficult to identify separately.

Erosion/corrosion is the result of the constant abrading of an oxide layer that forms on the interior surface of the pump liquid end. This protective oxide

DEFINING YOUR APPLICATION AND CONSTRAINTS

layer is the beneficial chemical reaction between the metal parts and the slurry transport liquid. It protects the metal parts from corrosion however, when it is constantly being abraded, this breakdown exposes the underlying metal to the particles and erosion/corrosion takes place and removes the metal.

Many gaseous and liquid environments commonly degrade elastomers. Elastomers vary in their ability to absorb a gas or liquid and in their tendency to be dissolved in a solvent. When partial absorption or dissolution occurs, elastomers dilate causing a drastic affect on strength and modulus of elasticity of the material. This results in a deterioration of the wear resistance of the elastomer.

Chemical resistance is a broad term used to describe the deterioration of materials when they are immersed in either a static or dynamic fluid.

In the case of an elastomer, chemical resistance may refer to resistance to corrosion or resistance to dilation, and subsequent loss of strength.

Solids Concentration

The adverse effects on pump performance caused by solids in a slurry, rather than clear water, are principally due to:

- Slip between the fluid and the solid particles during acceleration and deceleration of the slurry while entering and leaving the impeller. This slip of solids, and the associated energy loss, increases as the settling velocity of the particles in the slurry increases.
- Increased friction losses in the pump. These losses increase with the density (and bulk viscosity) of the slurry.

NOTE: In the following text "Head" (H) is the total head developed by the pump, expressed in feet of the actual liquid or mixture being pumped. For pumping water, we designate the total head developed by the pump as H_w (expressed in feet of water) and for pumping a slurry mixture we use the term H_m (expressed in feet of slurry mixture).

The expression Head Ratio (HR) is the ratio: H_m/H_w when the pump handles the same flow rate of water (for H_w) or mixture (for H_m) and the pump speed is the same, in both cases.

The HR is equal to one (1) for water but decreases as the concentration of solids increases in the slurry mixture. The HR for any given slurry is affected by the particle size and specific gravity of the solids, as well as the volumetric concentration of solids in the mixture.

The HR cannot be determined theoretically, but an empirical formula has been developed, from numerable tests and field trials, that allows reliable estimates in most cases.

In addition to lowering the head developed by the pump, a rise in solids

concentration also reduces the pump efficiency. At high concentrations, this reduction in efficiency could be considerable. For any given pump, it becomes more pronounced with an increase in the size of the particles being pumped.

NOTE: In the following text, the symbol “ e_w ” is used to indicate the pump efficiency when pumping water while “ e_m ” denotes the pump efficiency when pumping a slurry mixture.

The expression Efficiency Ratio (ER) is the ratio: e_m/e_w when the pump is handling the flow rate of slurry mixture or water and the pump speed is the same, in both cases.

Figure 2-3 has been developed, from test and field results, to enable a reasonable estimation of HR and ER in most practical cases. Using this chart, the pump speed required by a centrifugal pump when pumping a slurry mixture will be higher than that indicated by the clear water performance curves.

Similarly, the power required by a centrifugal pump pumping a slurry mixture will be higher than the value indicated by simply multiplying the clear water power value by the specific gravity of the slurry mixture (S_m).

The size of the particle pumped has less and less impact on the pump's performance as the impeller size increases.

NOTE: This chart applies to simple mixtures of SOLIDS AND WATER ONLY.

Effects On Material Selection

The properties of the slurry have a direct relationship to the types of materials required for the components within the slurry pump. Further details on the effects of slurry properties on various types of materials can be found in Section 1, page 1-5. For details of the various material options available, refer to Section 5.

Volume/Flow Rate

The volume of slurry to be transported must be reliably determined before defining a slurry pumping application. Without a clear understanding of the volumetric requirement and possible variations of demand, it would be impossible to adequately compute a pumping system solution. For slurry pumping, the volume (or flow rate) is determined by a correlation between three factors:

- the solids specific gravity (SG),
- the tonnage of solids required to be pumped, and
- the concentration of these solids within the slurry mixture.

These three factors need to be determined prior to selecting any slurry pump. An example of how the flow rate can be calculated using these values is given in Section 3.

DEFINING YOUR APPLICATION AND CONSTRAINTS

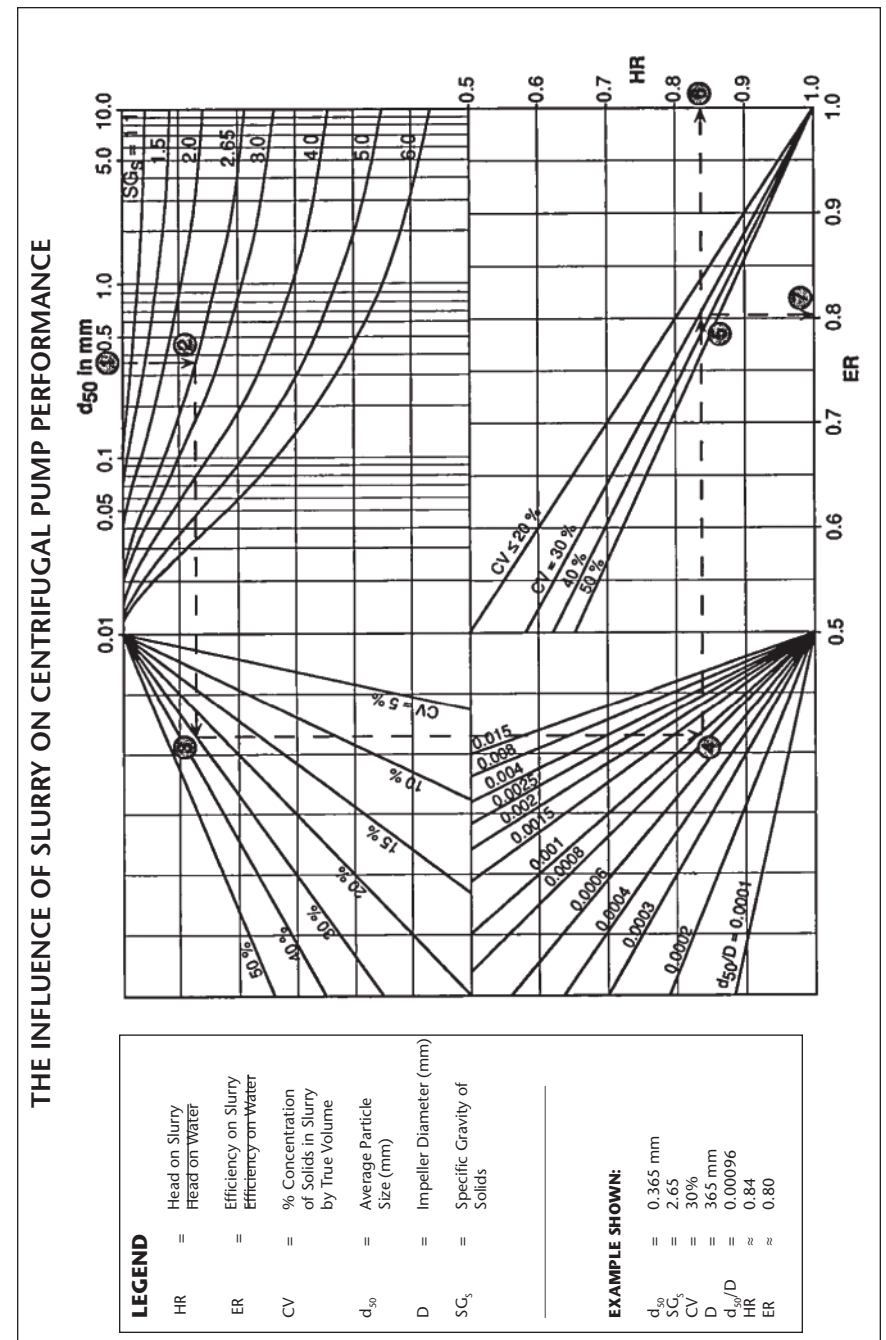

Figure 2-3 Performance of Centrifugal Pumps on Slurry

Pipeline Length

Another prime requisite for the evaluation of a slurry pump system is the determination of the length of the pipeline to be used in the application. Slurry passing through a pipeline creates friction (or drag) against the pipe walls. The longer the pipeline, the greater the friction force to be overcome by the slurry pump. Prior to any pump selection, it is imperative that the actual length of the pipeline and details of bends or other pipe variations be established as accurately as possible. Further details on the calculation of pipeline friction can be found in Section 6.

Static Head Required

The actual vertical height (static head) which the slurry is to overcome must be determined accurately prior to selecting a pump. This is a relatively easy in-plant situation where the vertical heights involved can be measured or obtained from drawings. In the case of overland pipelines, surveying data is often required to obtain this vital information. Variations in the vertical height (normally measured from the liquid level on the intake side of the pump to the discharge point or the high point in the line) can have a major effect on the output of any centrifugal pump. It is, therefore, important that this vertical height be determined within reasonable accuracy (1.5 ft.) prior to pump selection. Further details of this important element of slurry pumping can be found in Section 7.

Pipe Size

The selection of the optimum pipe diameter is also critical in any slurry pumping system. The use of a pipe that is too small can result in either insufficient flow rate or excessive power consumption. By way of example, a typical slurry flow rate of, 1600 gpm pumped over 3300 ft. would generate friction of 3920 feet in a 4" I.D. pipe versus only 535 feet in a 6" I.D. pipe. Theoretical power consumption would be around 2700 hp for the 4" pipe compared to only 357 hp for the 6" pipe.

The velocity at which the slurry is pumped within the pipeline (determined by the flow rate and the pipe diameter; please refer to Page "x" for pipe velocity equation) must also be evaluated to ensure sufficient velocity will be available to maintain the solids in suspension while they are being pumped. If insufficient velocity is available, the solid particles will progressively settle within the pipe and ultimately cause a total blockage of the pipe.

For further details on pipe size and selection, refer to Section 6 and Section 8.

DEFINING YOUR APPLICATION AND CONSTRAINTS

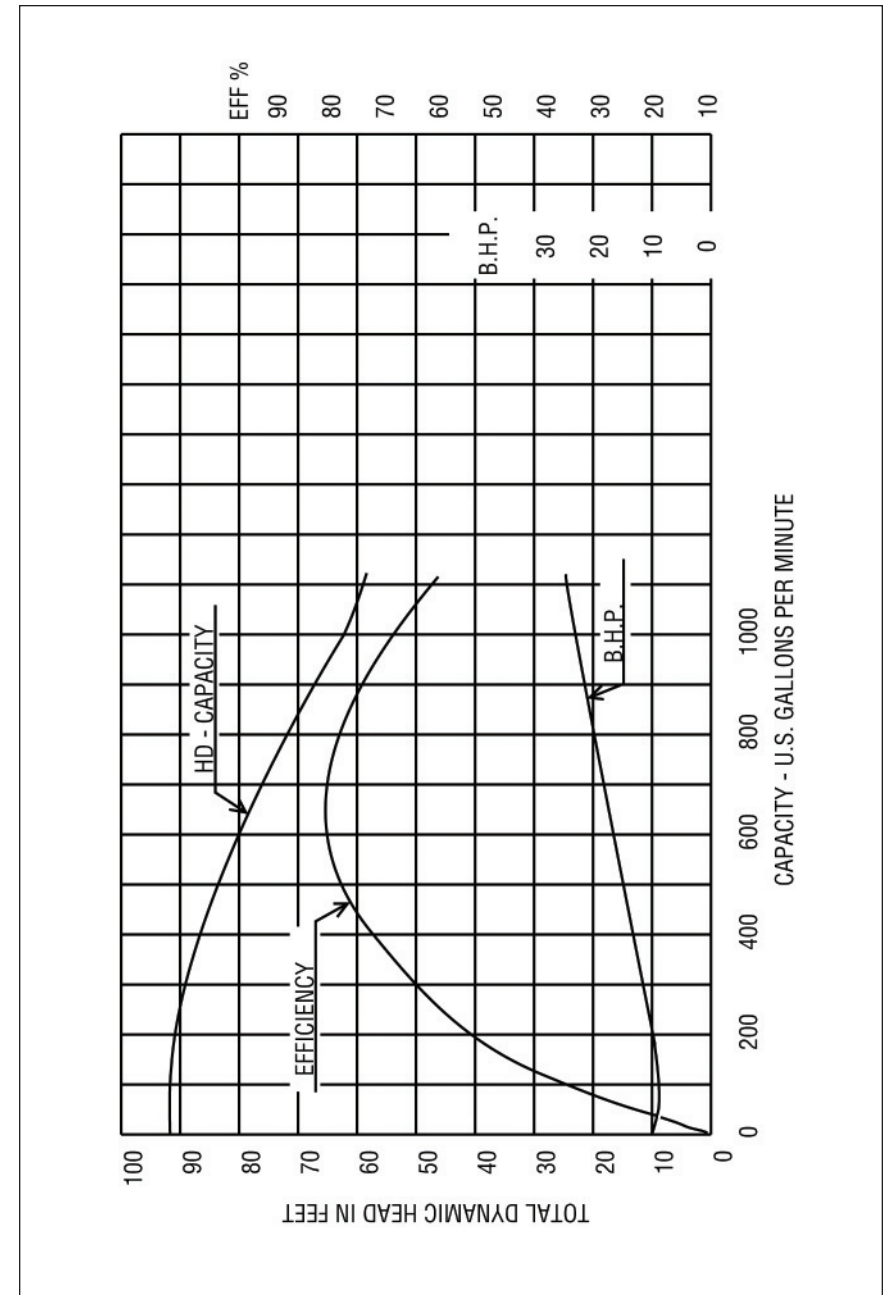

Figure 2-4 Typical Pump Performance Test Graph On Water

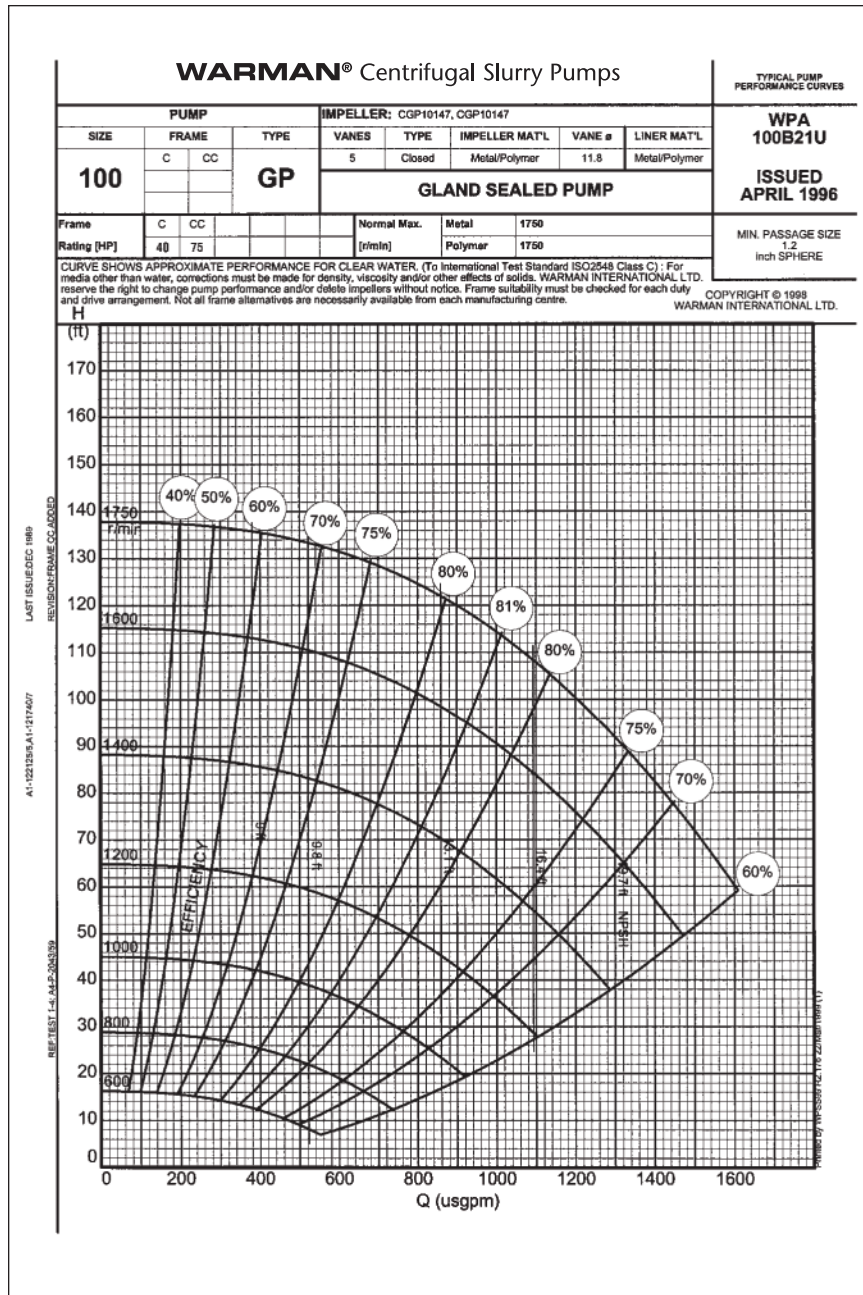

Figure 2-5 Typical Pump Performance Graph

Pump Performance Graphs

To understand the performance of a centrifugal pump, it is necessary to understand how the performance of individual pumps are determined and presented.

Centrifugal slurry performance is usually presented in the form of a performance graph with the flow rate and the head being plotted for a constant speed. Every individual pump model is subjected to a performance test (normally using clear water) at various speeds to compose a performance graph showing its full range of capabilities. A typical pump test performance graph is shown in Figure 2-4 with a typical pump performance curve, as issued by Warman, shown in Figure 2-5.

System Resistance Curves

The characteristics of a centrifugal pump do not allow a fixed capacity output (as with positive displacement pumps) but rather balance the output against the back pressure of the pipe system. The friction in any pipe system increases with flow rate and can be plotted on what is known as a system resistance curve, as shown in Figure 2-6. The intersection of the pump performance curve and the pipe system resistance curve determines the actual duty point at which the pump will operate. This is demonstrated in Figure 2-7. The pipe system can be defined as all the piping, fittings and devices between the free surface liquid level on the intake side of the pump, to the point of free discharge at the output end of the pipe.

Details on determining the relevant losses that occur in any given system are shown in Section 6.

Centrifugal slurry pumps must overcome both the static head and the system resistance to achieve the movement of slurry to the output end of the pipe system.

This system resistance curve is, in fact, unique to any particular piping system and cannot change unless something in the pipe system is changed, for example:

- increasing or decreasing the length of pipeline,
- changing fittings,
- varying the pipe's diameter, or
- varying the static head.

Friction loss is usually established for water and a correction is made to account for variations in the slurry concentration as described in Section 6.

Determining the system resistance curve is important when evaluating any slurry pump application to assess the duty point and impact of potential flow rate variations correctly.

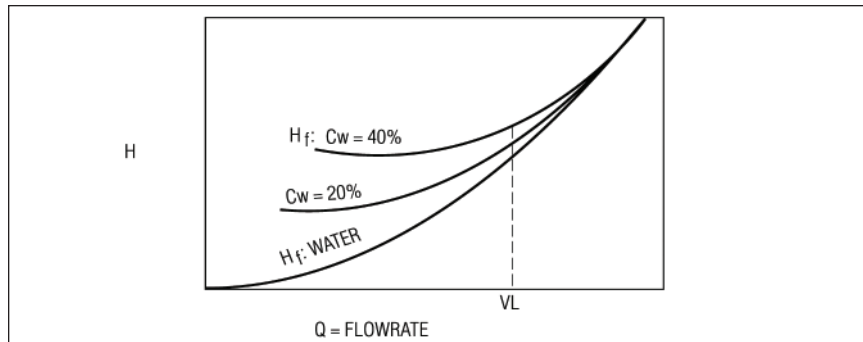

Figure 2-6 Typical System Resistance Curve

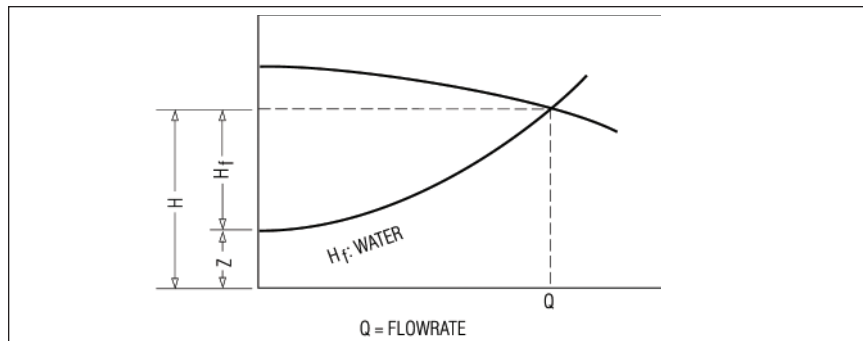

Figure 2-7 Typical Duty Point Curve

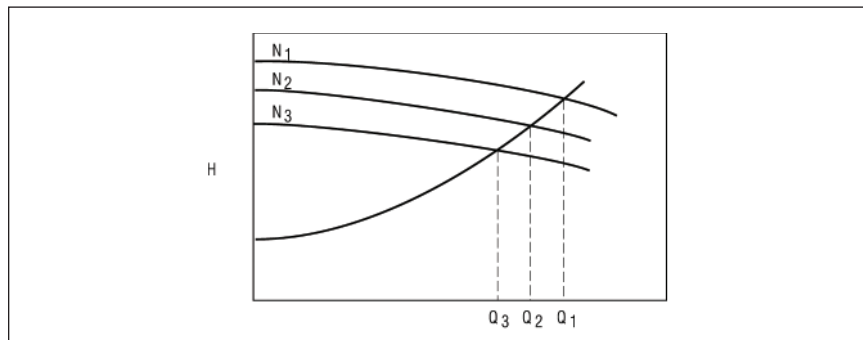

Figure 2-8 Typical Graph Showing Pump Speed Variations

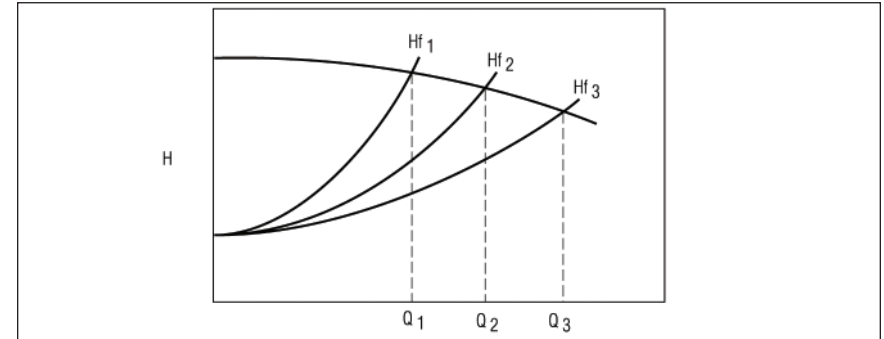

Figure 2-9 Typical Graph Showing System Variations

System graphs, such as Figure 2-8 and 2-9, are helpful in determining the effects of altering the pump speed or altering some aspect of the pipe system.

Figure 2-8 demonstrates the change in flow rate caused by changing the pump speed.

Figure 2-9 demonstrates the change in flow rate caused by changing some aspect of the pipe system.

Other Design Constraints

Shaft Sealing

The shaft seal is one of the most important mechanical elements in any centrifugal slurry pump and the correct type of seal must be carefully selected to suit each individual pump system. The three most commonly used seal types are as follows:

Centrifugal (or Dynamic) Seal

The centrifugal seal is a dynamic, dry seal that only operates while the pump is rotating and has no seal effect when the pump is stationary. A secondary seal maintains the liquid within the pump when it is stationary. The secondary seal can be either a rubber lip seal or a grease lubricated packing as illustrated in Figure 2-10a.

The centrifugal seal consists of expelling vanes on the back of the impeller and an expeller which rotates in unison with the impeller located in a separate chamber behind the impeller. The expeller acts as a turbine to reduce the pressure of the slurry attempting to escape around the back of the impeller. The expeller forms a pressure ring within the expeller chamber and prevents the slurry from passing into the secondary seal area.

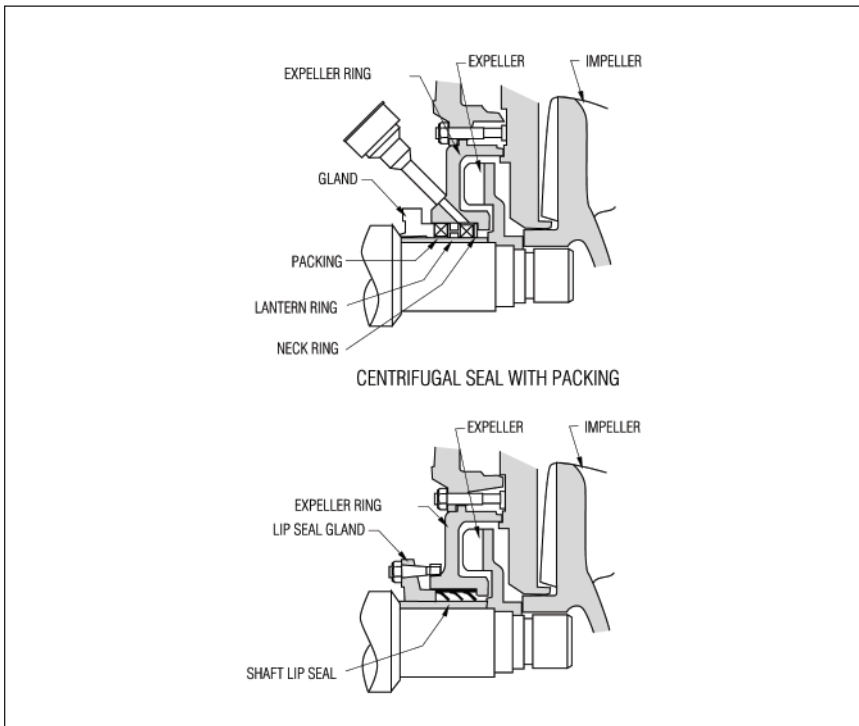

Figure 2-10a Centrifugal (or Dynamic) Seal Arrangements

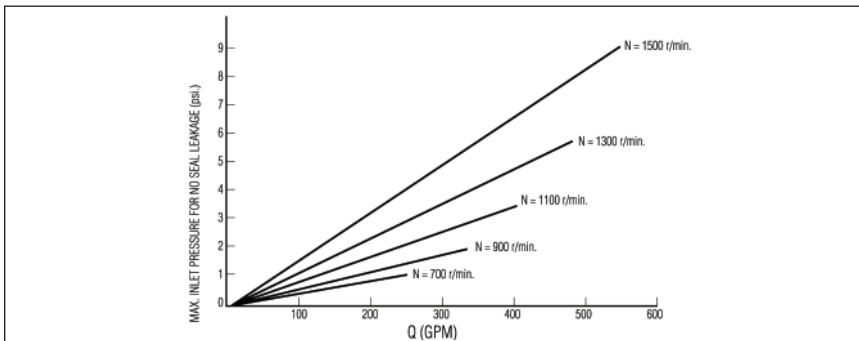

Figure 2-10b Typical Centrifugal Seal Performance Curve

Because of its effectiveness and simplicity, the centrifugal seal is the most common seal used in slurry applications, but it is limited by the pump inlet pressure and the pump speed, (rpm). Performance data is available for centrifugal seal limitations for specific pump sizes generally as shown in Figure 2-10b.

Gland Seal

The soft, packed gland seal is the second most commonly used seal in slurry applications. The gland seal comprises a number of soft packing rings, compressed against a chamber (stuffing box) and a protective wear sleeve which is fitted to the pump shaft. This type of seal requires continuous clean liquid lubrication and cooling between the rotating shaft sleeve and the compressed packing to prevent overheating due to the friction.

The quality, quantity and pressure of this gland sealing water is of prime importance and must be carefully matched to the duty required. The gland arrangement is shown in Figure 2-11. Note: This gland seal arrangement can be provided as a low flow seal by substituting the stainless steel lantern restrictor with a close tolerance P50 (see page 5-6) lantern restrictor. This will reduce the gland water consumption by at least half.

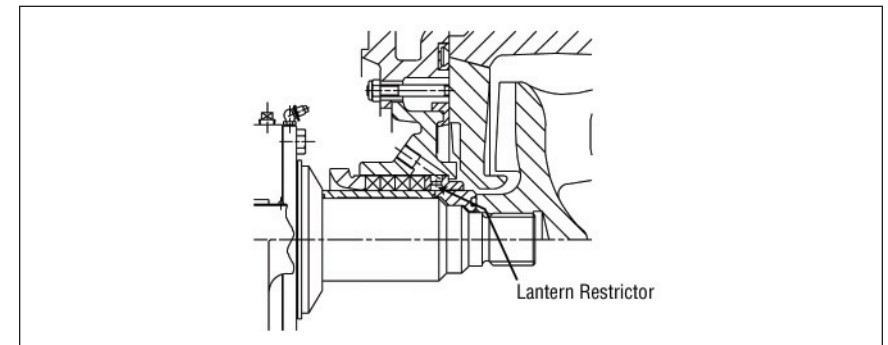

Figure 2-11 Gland Seal Arrangement

Mechanical Seal

Mechanical seals are not widely used in slurry applications but their use in special circumstances are increasing. The mechanical seal consists of a stationary and a rotating face pressed together under mechanical and hydraulic pressure to prevent leakage.

Alpha-grade silicon carbide or tungsten carbide are the most common materials used for manufacture of these seal faces.

The use of mechanical seals in slurry applications requires extreme care and attention due to the limited reliability common in this developing product. Seal costs are relatively high and require substantial justification to warrant their use.

Seal specialists are actively developing this type of seal expecting that a greater reliability and lower production costs will lead to an increase in use. Applications where a centrifugal seal cannot be used, and where the addition of water cannot be tolerated, provide the most likely areas for the use of mechanical seals.

One of the subtle benefits of the Warman pump design is found in the fixture of the anti-friction bearings found on the rotor. While other manufacturers allow the inboard radial bearing to "float" in the housing, Warman fixes that bearing in place. This feature, in conjunction with the short cantilever to the impeller and generously dimensioned shaft, produces a rotating element of unusual rigidity and resistant to deflection. Additionally, the shorter shaft length between the fixed radial bearing and the mechanical seal faces lessens the likelihood of encountering thermal growth problems that could over-pressurize the sealing faces. This is paramount in providing a mechanical environment that will yield maximum service life for a mechanical seal. A typical seal arrangement is shown in Figure 2-12.

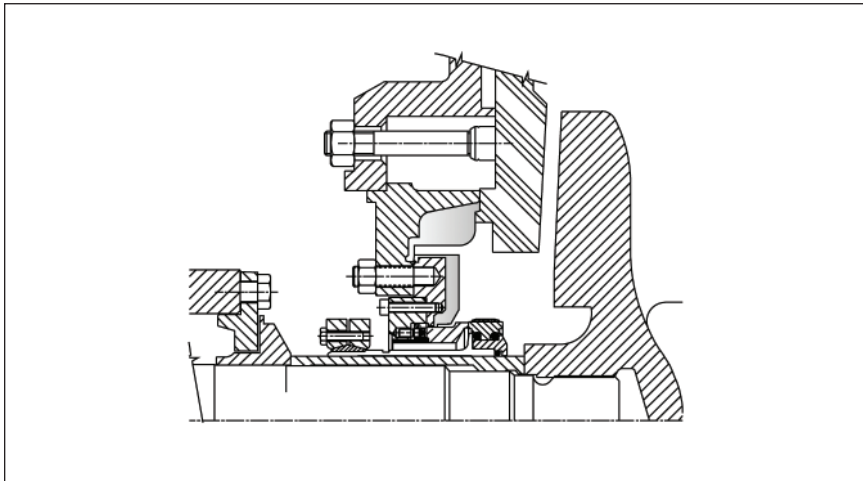

Figure 2-12 Typical Mechanical Slurry Seal

Pump Sumps

It is often the case for low to medium head duties, where the head and quantity requirement is fixed (or nearly so), to operate the pump at a fixed speed and allow the liquid level on the intake side of the pump to vary naturally.

The variation in liquid level is usually made possible by the use of a pump sump or some other form of feed tank.

Figure 2-13 illustrates a typical sump feed system and the natural flow control principle. Important features of the design are as follows:

- a. The height must be sufficient to provide an adequate reserve.
- b. The bottom must be sloped at a minimum of 30°, to hinder the accumulation of settled solids.
- c. The liquid surface area must be sufficient to allow a continuous release of entrained air or froth at the free liquid level.
- d. The outlet axis at the base of the sump should be sloped at a minimum of 30° to allow air in the suction pipe to be easily displaced, (particularly on start-up).
- e. The suction pipe should be as short as possible to facilitate the displacement of air on start-up after the pump has been off-line or after the pump has lost its prime.
- f. The suction pipe should also incorporate a removable, flexible coupling of sufficient distance from the pump flange, to provide access to the pump for maintenance. The support for the remainder of the pipework should be independent of the pump.
- g. A breather pipe is recommended and other special considerations should be made, when the pump is to handle aerated, frothy or very viscous slurries. (Refer to #3 on the following page for more details).
- h. The suction pipe should incorporate a scuttle plug branch in order to drain the pump and the sump.

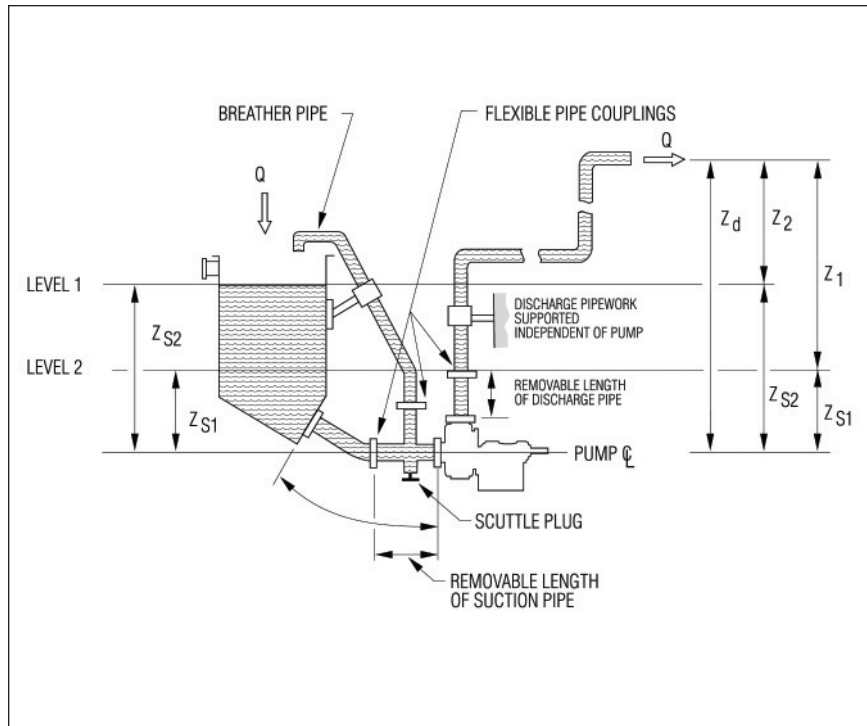

Figure 2-13 Typical Pump Sump And Natural Flow Control Principle

Air Locks

Horizontal pumps which are gravity-fed from a conventional sump filled with frothed slurry may operate in an unstable (cyclic) manner. The output of the pump will oscillate between full and zero flow rate.

Intermittent air locking causes this cyclic performance. The centrifugal action of the impeller selectively centrifuges slurry away from the eye of the impeller, leaving a growing air bubble trapped at the eye. This accumulation of air impedes the movement of froth from the sump into the pump and eventually the pump flow rate will reduce to zero. Consequently, the intake liquid level increases until it is sufficient to compress this air bubble, allowing the froth to reach the impeller and full flow rate is restored. Air will again begin to accumulate, repeating the cycle.

If the intake liquid level in the sump is insufficient to compress the entrapped air bubble, then flow through the pump will not restart until the pump is stopped long enough to allow the bubble to escape.

This tendency to produce air locks may be avoided, or minimized, by providing a vent pipe to allow the trapped air to be released continuously, as shown in Figure 2-14.

DEFINING YOUR APPLICATION AND CONSTRAINTS

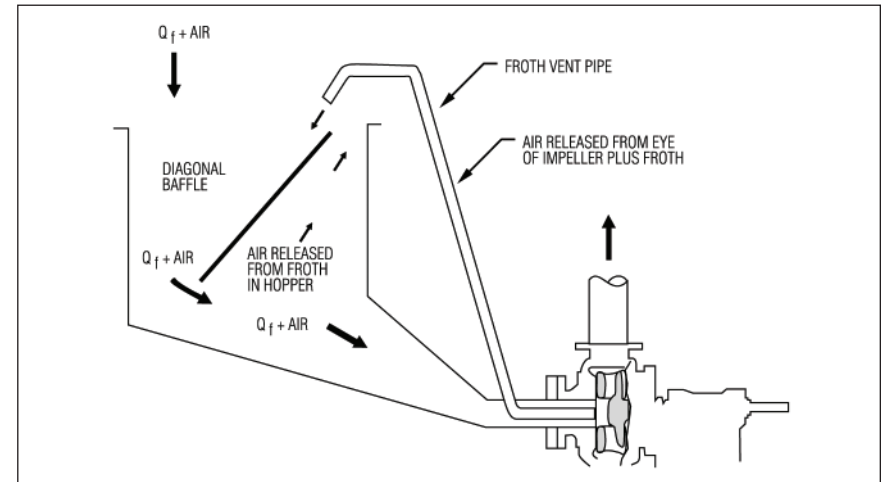

Figure 2-14 Typical Pump Sump Arrangement for Aerate/Frothy Slurries

This arrangement is similar to a normal vent pipe installation, except that the froth vent pipe is extended into the eye of the impeller (to reach the air bubble held by the centrifugal action). The sump is generally oversized to increase the pressure on the entrapped air bubble.

Sometimes a diagonal baffle is also fitted to the sump to minimize the regeneration of froth and to assist the escaping air. The feed pipe from the sump should be extended to a large conical or pyramid shape, to provide an increased entry area for the froth as close as possible to the pump.

Another solution may be to index the pump heads to the +315° or +270° position (see Figure 2-15) which prevents the entrapment of air in the upper portion of the casing by the cutwater. This trapped pocket of air would be displaced towards the eye of the impeller when the pump is started if "Standard Vertical" or other dispositions are selected, see Figure 2-15.

A pump with an oversized suction like the Warman AHF/LF/MF pump has been very successful in greatly reducing froth pumping problems. The AHF/LF/MF is a simple modification to the standard AH/L/M slurry pumps. The current AH/L/M can be retrofitted to the new model by replacing a few parts to enlarge the suction to more easily handle the froth.

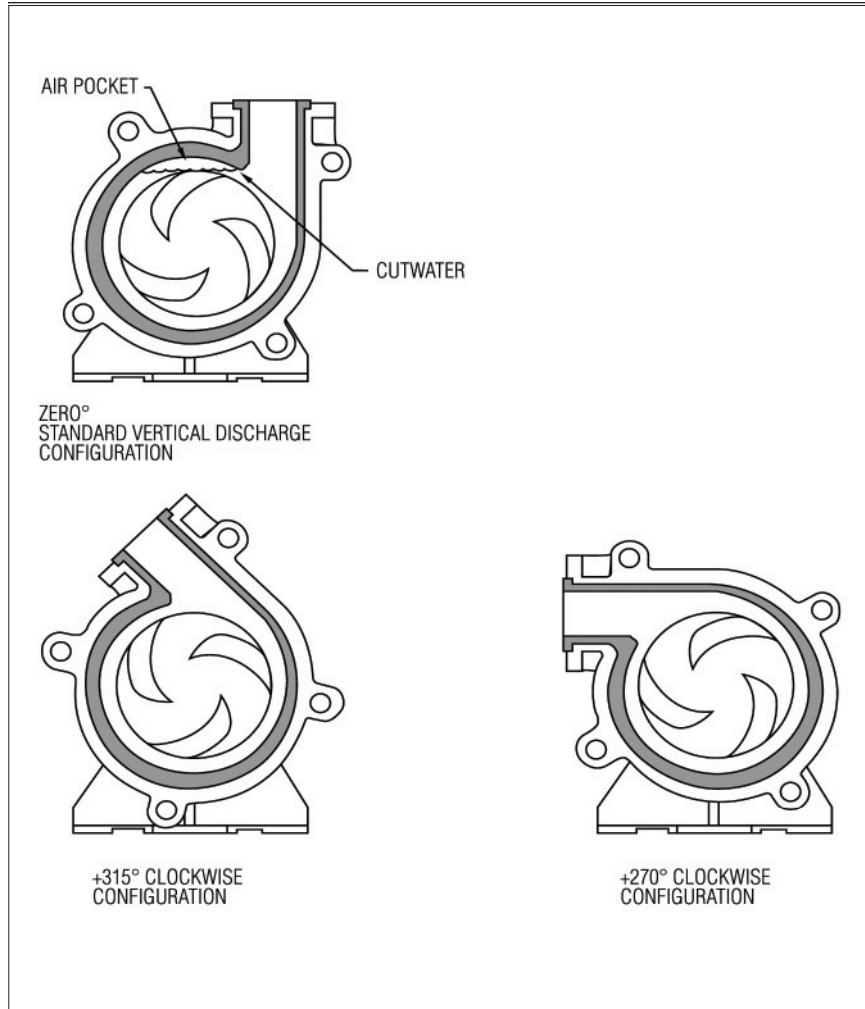

Figure 2-15 Pump Discharge Orientation To Minimize Air Locking

Head Loss At Exit Into Pressure-Fed Equipment

The exit velocity head, H_{ve} , must be accounted for as a Head Loss when the slurry is discharged under pressure into Pressure-Fed equipment, such as hydraulic cyclones, (see Figure 2-16) or filter-presses.

$$H_d = Z_d + H_{fd} + H_{ve} + H_{pf}$$

$$= H_{gd} + H_{vd}$$

where $H_{ve} \approx H_{vd}$ = the velocity head in the pipe at the point where H_{pf} is measured with a gauge.

NOTE: If the value of H_{pf} is specified the value must allow for all the head losses downstream of the point of evaluation of H_{pf} .

DEFINING YOUR APPLICATION AND CONSTRAINTS

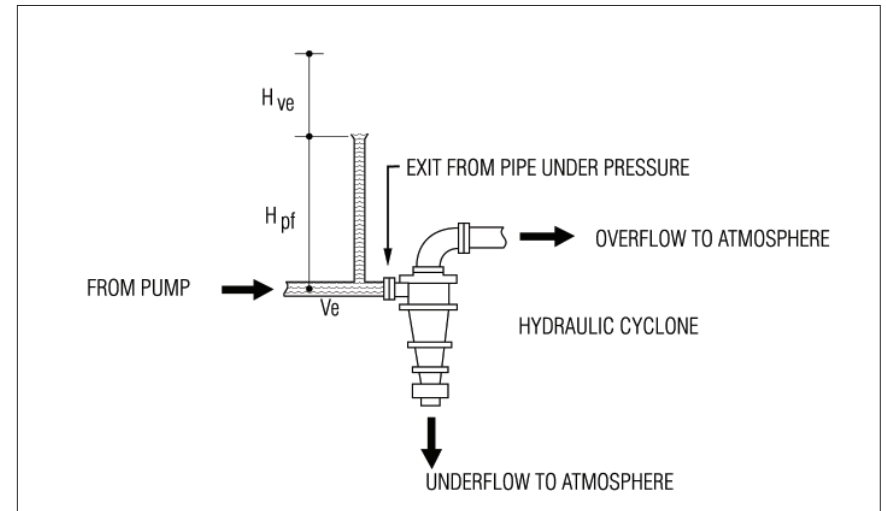

Figure 2-16 Typical Cyclone Arrangement

Pump Bursting Hazard

The potential hazard presented by operating any centrifugal pump, while the intake pipe and the discharge pipe are simultaneously blocked, is generally well known. The resultant heat generated can result in vaporization of the entrapped liquid, which in extreme cases, has been known to cause violent bursting of the pump casing.

This potential hazard may be increased when centrifugal pumps are used in slurry applications due to the nature of the material being pumped. The danger is that a slurry mixture is more likely to cause an accumulation of solids which block the pump discharge pipe and may remain undetected. This situation has been known to lead to a blockage in the intake side of the pump. The continued operation of the pump under these circumstances is extremely dangerous. Should your installation be prone to this occurrence, preventive measures should be adopted to forewarn the operators of this situation.

Prior to selecting a pump, carry out the steps in Section 3.

Section 3 - Selecting the Appropriate Pump

Determine The Flow Rate

The flow rate can be evaluated in numerous ways, but is usually established by the volume of solids to be pumped and the proposed concentration of solids and liquid. An example of calculating the flow rate is given on page 3-6.

Determine The Static Head

The static head (vertical height on both the intake and discharge side of the pump) must be established, and the difference calculated to determine the net static head to be overcome by the pump.

Determine The Pump Head and Efficiency Corrections

The effect of the slurry on the pump's performance must be determined, as well. The items necessary to know are:

- the average particle size, d_{50} , of the solids to be pumped (d_{50} is the theoretical screen size where 50% would pass and 50% would be retained),
- the concentration of solids in the liquid (% by volume),
- the specific gravity (SG) of the dry solids, and
- the pump impeller diameter.

These four values can now be entered into the nomograph shown in Figure 2-3, to determine the Head and Efficiency correcting ratio (HR/ER).

Determine The Pipe Diameter

It is necessary to determine the pipe diameter that will be required to provide the optimum velocity to minimize friction while maintaining the solids in suspension (to prevent the solids from settling out of the flow).

Details can be found in Section 6 and Section 8.

Calculate The Friction Head Loss

The friction loss created by all the various elements of the pump system must now be calculated.

Further details on the calculation of the friction loss can be found in Section 6.

Calculate The Total Dynamic Head

The total dynamic head can now be calculated. Further details on these calculations are shown in Section 7.

Select Pump Type and Materials

Prior to the selection of a specific pump size, it is necessary to determine the pump type required and to establish the type of materials needed. A general description of the various types of Warman pumps available can be found in Section 4.

The basic concepts used in the selection of various materials can be found in Section 1 with details on available materials given in Section 5.

Pump Selection

A preliminary selection can now be made from the general selection chart for the various pump types supplied by Warman. A typical example of the Warman selection chart for lined, horizontal slurry pumps is shown in Figure 3-1.

Once the preliminary selection is made, the individual performance curve can then be considered.

Determine The Pump Speed

The speed required can now be determined from the relevant performance curve.

Calculate The Required Power

The power required can now be calculated as shown in the example in Section 3. This will also enable an appropriately sized motor to be selected.

Additional Design Considerations

NPSH

The Net Positive Suction Head should be evaluated to ensure that the pump selected will be capable of performing the duty without cavitating. Further data on NPSH can be found in Section 9.

Casing Pressure

It is necessary to calculate the maximum pressure in the pump (usually computed at the pump discharge) to ensure that the maximum pressure limits for the pump casing are not exceeded. Contact Warman for details of the pressure limits for particular pumps.

Froth Pumping

The actual flow rate of froth (slurry plus bubbles) to be handled can vary markedly, compared to the flow rate of slurry only (that is, without any bubbles). The Froth Factor may be as low as 150% for a less stable froth or as high as 500% for a very tenacious froth.

The slurry flow rate, Q , must be multiplied by the Froth Factor to determine the actual froth flow rate, Q_f , which is to be handled by the pump. Q and Q_f may also vary widely due to the variations in the grade and nature of minerals which are treated, from time to time, in a given flotation plant.

The presence of air bubbles in the froth reduces the effective value of the mixture's specific gravity (S_m) as the froth enters the pump. The compression of the bubbles by the head developed in the pump quickly increases the value of S_m . This value is subsequently decreased as the froth passes from the pump, along the discharge pipeline, to the discharge point which is at atmospheric pressure. Conversely, the mixture's discharge velocity (V_d) will increase along the pipeline due to expansion of the bubbles. Further details on considerations required for froth pumping are given in Section 2, pages 2-16 through 2-17.

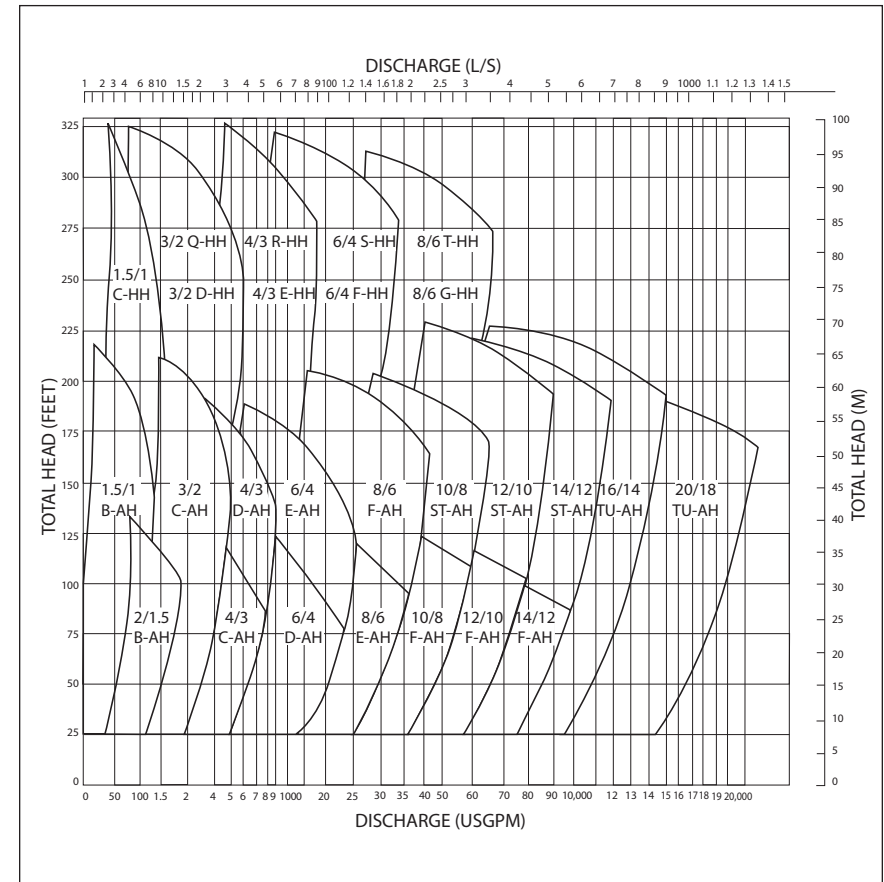

Figure 3-1 Typical Warman Preliminary Selection Chart

Conical Enlargements

In many cases, the discharge pipe's internal diameter may be greater than at the discharge flange of the pump selected. A conical enlargement section is required to join the pump to the pipework.

In order to minimize head losses and, in particular to avoid an excessively high wear rate of the conical enlargement and the adjacent pipework, a good design practice is to adopt the included angle, $\theta = 6^\circ$. In practical terms, this is equivalent to allowing an increase in diameter of .5 in. for every 5 in. in length of the conical section.

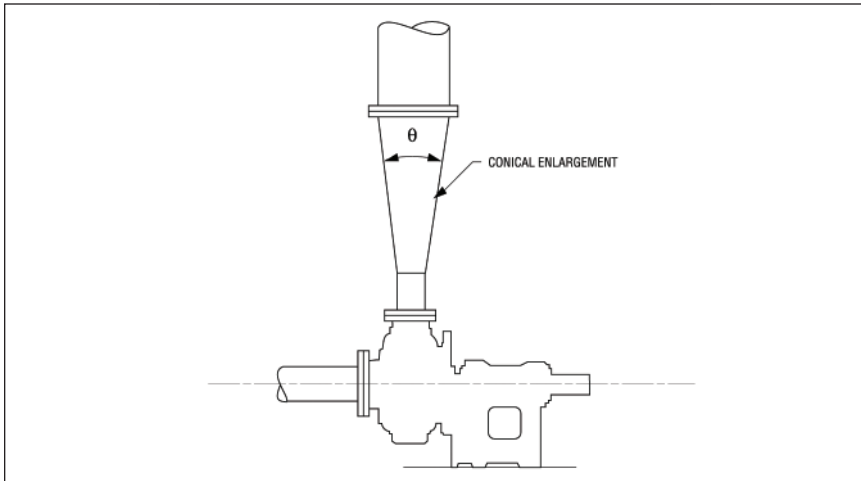

Figure 3-2 Typical Conical Enlargement

Pump Feed Sumps

Consideration should be given to the design of a suitable pump feed tank or sump. Some basic guidelines are given in Section 2.

Shaft Sealing

It is important that the correct type of shaft seal is selected to suit the specific duty conditions. Further details on the various types of seals available can be found in Section 2.

Multi-Staging

Where the duty required exceeds the head capabilities of a single pump, multiple pumps in series may be required. Further details on the requirements for series pumping can be found in Section 10.

Drive Selection

Direct coupling to fixed speed motors is common with non-slurry type centrifugal pumps. Duty variations are usually accommodated through changes in impeller diameter.

For slurry pumps, impellers are manufactured in hard metal white irons or metal reinforced elastomers. It is usually not economical or practical to reduce the

diameter of standard impellers to meet specific duty requirements. Standard-diameter slurry pump impellers are recommended for most abrasive applications. The optimum pump speed, or speed range, can be achieved by suitable means, (for example, v-belt drive or variable speed drives), to meet the duty requirements. The lowest speed results in the lowest power consumption and the lowest wear rate for any given Warman slurry pump applied to a given duty.

Progressive speed changes are beneficial by providing the lowest practical pump speed to handle the required duty at any given time. On some duties, the required pump speed may have to be varied progressively, possibly over a relatively wide range,

- due to wear,
- in order to maintain the intake static head at a constant value, or
- due to variations in required flow rate, static head, pipeline length exit pressure head or solids concentration.

Typical examples are:

- tailings disposal,
- mill classifier (cyclone) feed in closed-circuit grinding operations, and
- some variable suction dredging duties.

For duties up to approximately 400 hp, v-belt drives from a fixed-speed motor are commonly employed (although belt drives have been installed on 1250 bhp diesel driven slurry pumps). The pump speed may be changed as required by occasional changes in sheave ratios (for example, a larger diameter motor pulley may be fitted). Where frequent variations are required, this solution is unattractive because the pump must be stopped to change speed and the speed changes are stepped.

The most effective means of satisfying these progressively varying requirements is to provide for an efficient variable speed drive of either a mechanical or electronic design.

Where a motor size exceeds the practical limitations for v-belt applications, a direct coupled motor in conjunction with a speed reducing gear box may provide the most practical solution.

Throttle valves are not recommended for use in slurry systems to control flow rate (by head loss), due to the resultant higher values of head, speed and wear on pumps and valves and due to the increased power required. An additional consideration is the increased risk of pipeline blockages.

Typical Pump Calculation

A heavy duty slurry pump is required for the following duty:

70 tons per hour of sand

Specific gravity of solids S	=	2.65
Average particle size d_{50}	=	211 microns (0.211 mm)
Concentration of solids C_w	=	30% by weight
Static discharge head (Z_d)	=	65 ft
Suction head (Z_s)	=	3 ft (positive)
Length of pipeline	=	325 ft
Valves and fittings	=	5 X 90° long radius bends

The pump will be gravity fed from a sump and be arranged generally as shown in Figure 3-3.

Pump size, speed, shaft power and recommended size of delivery pipeline are determined below.

Quantity Pumped

The quantity to be pumped can be determined thus:

a. Weight of solids in slurry	=	70 tons
b. Weight of volume of water equal to solids volume	=	$\frac{70}{2.65} = 26.4$ tons/hour
c. Weight of water in slurry of $C_w = 30\%$	=	$\frac{70(100-30)}{30} = 163.33$ tons/hr
d. Total weight of slurry mixture hour add (a) and (c)	=	$70 + 163.33 = 233.33$ tons/
e. Total weight of equal volume of water hour add (b) and (c)	=	$163.33 + 26.4 = 189.73$ tons/
f. Specific gravity of slurry mixture (S_m) divide (d) by (e)	=	$\frac{233.33}{189.73} = 1.23$

g. Quantity of slurry	=	$\frac{189.73 \times 2000}{60 \times 8.34} = 758$ gpm where water weighs 8.34#/gal.
h. Concentration of solids by volume (C_v) divide (b) by (e) X 100	=	$\frac{100}{189.73} \times 26.4 = 13.9\%$

Size Of Pipeline

A 6 inch pipeline is selected as being potentially suitable and is checked as follows:

The slurry mixture velocity is determined by the following formula:

$$V = \frac{Q \times .4085}{d^2}$$

where	V	=	slurry velocity in feet/second
	Q	=	slurry flow rate in gpm
	d	=	pipe diameter in inches

Velocity V in this case is therefore:

$$\frac{758 \times .4085}{6^2} = 8.60 \text{ feet/second}$$

Using Durand's equation from Section 8.

$$V_L = F_L \sqrt{2gD \frac{(S-S_L)}{S_L}}$$

where	D	=	Pipe diameter in ft
	g	=	32.2 feet/second ²

The value of F_L is obtained from Figure 8-2, using a C_v of 13.9% and an average particle size $d_{50} = 211$ microns. (For widely graded particles.)

$$\text{Value of } F_L = 1.04$$

By substitution of values in Durand's equation the limiting settling velocity V_L becomes:

$$V_L = 1.04 \sqrt{2 \times 32.2 \times .5 \times \frac{(2.65-1)}{1}} = 7.58 \text{ ft/sec.}$$

The 6 inch pipe is therefore considered suitable for this application since the limiting settling velocity (7.58 ft/sec.) is lower than the actual slurry mixture velocity (8.6 ft/sec.)

Friction Head H_f For The Pipeline

First determine the equivalent length of pipeline using the valves and fittings head losses table as shown in Figures 7-3 and 7-4.

$$\begin{aligned} \text{Actual length of line} &= 325 \text{ ft} \\ 5 \times 90^\circ \text{ long radius bends} \\ \text{at 11.0 ft each} &= 55 \text{ ft} \\ \text{Equivalent length of line} &= 380 \text{ ft} \end{aligned}$$

Using the steel pipeline size of 6 inch and a slurry mixture velocity of 8.6 ft/sec., the value $f = 0.0163$ is obtained from Figure 6-2.

By substitution in Darcy's equation for friction head in Figure 6-2:

$$\begin{aligned} H_f &= f \times \frac{L}{D} \times \frac{v^2}{2g} \\ &= 0.0163 \times \frac{380}{.5} \times \frac{(8.6)^2}{2 \times 32.2} \\ &= 14.23 \text{ ft of mixture for 380 ft of pipe} \end{aligned}$$

Loss In Discharge Pipe Enlargement

It is also likely that a divergent pipe section will be required in the discharge pipe as a preliminary review of pump selections (Figure 3-1) indicates a pump with a 4 inch diameter discharge to be a likely selection. A pipe transition piece would be required in this case to enlarge the discharge to the 6 inch pipeline size.

This is dealt with in Figure 7-4. Head loss in this case using an enlargement included angle of 30° would be:

$$K_e \frac{(V)^2}{2g} = \frac{0.55 \times (20.4 - 8.6)^2}{2 \times 32.2} = 1.19 \text{ ft}$$

Loss At Pipe Discharge

Under normal open discharge conditions, the velocity head at the pump discharge must be added to the required total head.

In this case, the velocity head $v^2 / 2g$

$$\text{is } \frac{(8.6)^2}{2 \times 32.2} = 1.15 \text{ ft of mixture}$$

Loss Of Head At Entrance To Suction Pipe

This is dealt with in Figure 7-4. The suction pipe, in this case, is most likely to be similar to the discharge (6 inch). Assuming the sump would be fitted with a flush type connection, the appropriate loss would be:

$$0.5 \times \frac{v^2}{2g} = .5 \times (8.6)^2 / 2 \times 32.2 = .57 \text{ ft}$$

Total Dynamic Head On The Pump (refer to Figures 7-1 and 7-2)

$$H_m = Z + H_f$$

where Z is static head; ie: $(Z_d - Z_s)$

$$\begin{aligned} H_m &= (65-3) + 14.23 + 1.19 + 1.15 + .57 \\ &= 79.14 \text{ ft of slurry mixture} \end{aligned}$$

Equivalent Water Total Dynamic Head

From Figure 2-3, we are able to determine that the appropriate correction (HR/ER) in this case is 0.95 based on the preliminary selection of a 6/4 DAH which has a 14.8" impeller.

The total head of equivalent water (H_w) is therefore:

$$H_m / HR = 79.14 / 0.95 = 83.3 \text{ ft of water}$$

Pump Selection

The pump can now be selected, using the required flow rate of 758 GPM.

Total head of 83.9 ft of equivalent water and a slurry SG of 1.23.

In this case, a Warman 6/4 D-AH heavy duty rubber lined pump is selected with a 5 vane closed rubber impeller at a pump speed of 1067 rpm (from Figure 3-4).

The absorbed power at the pump shaft can be computed using a pump efficiency of 67% (from Figure 3-3) thus:

$$\begin{aligned} \text{BHP} &= (Q \times H_m \times S_m) / (3960 \times \text{ew} \times \text{ER}) \\ &= (758 \times 79.14 \times 1.23) / (3960 \times .67 \times .95) = 29.27 \text{ HP} \end{aligned}$$

in this case, a 40 HP drive motor would be selected.

Note: In the case above, the HR = ER. To determine BHP, use the Slurry Head (H_m) of 79.14 and apply the ER as shown.

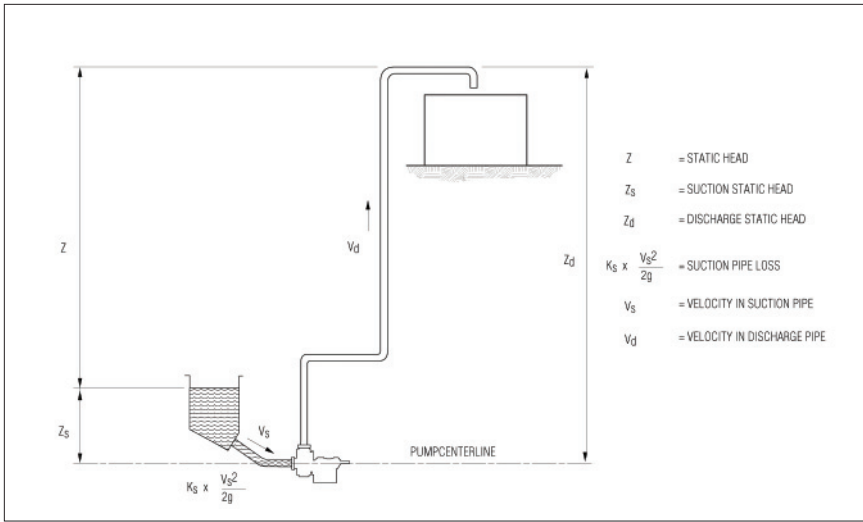

Figure 3-3 Typical Pump Application

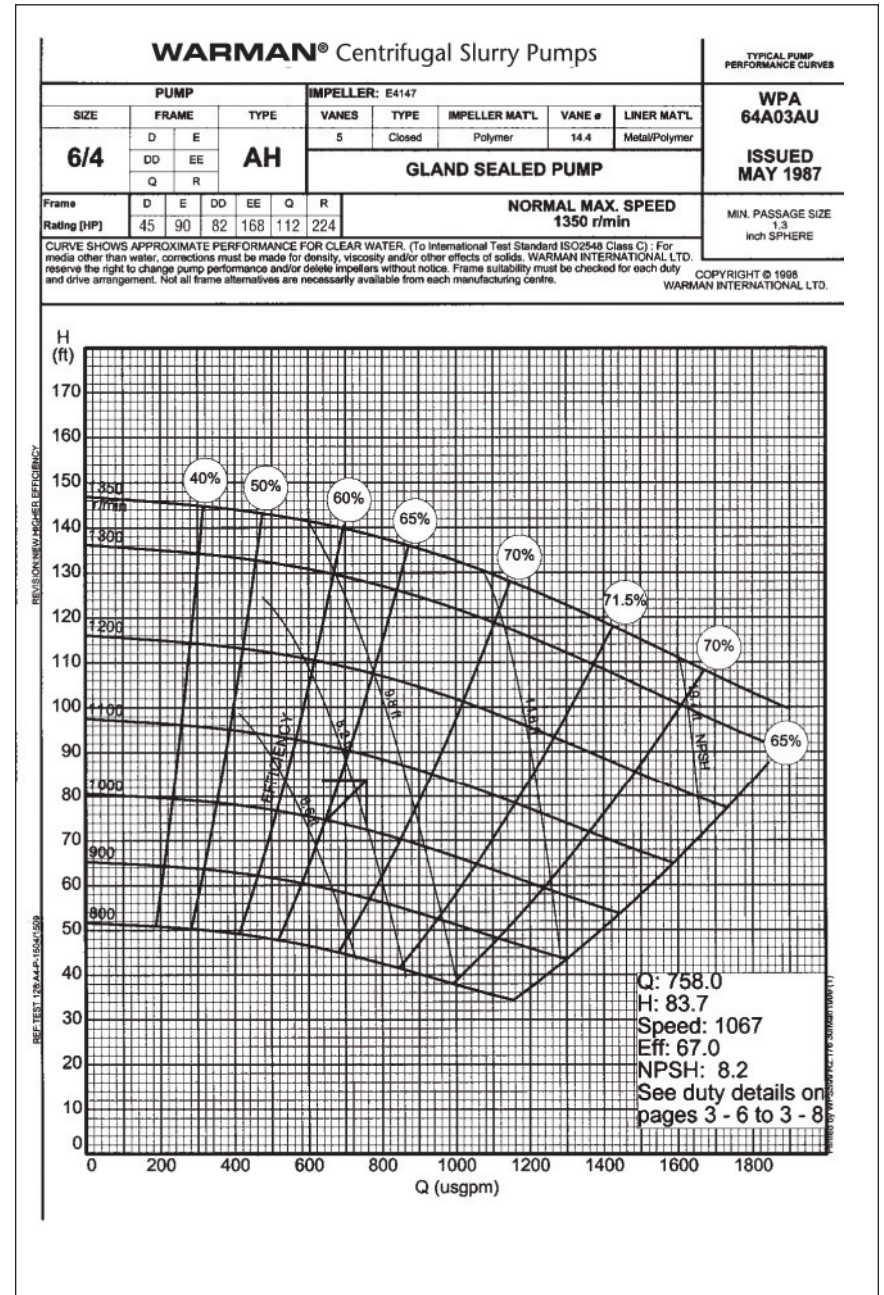

Figure 3-4 Warman Pump Performance Curve

Section 4 - Pump Types

Introduction

Warman slurry and liquor pumps are generally centrifugal (except for jet pumps) with the range consisting of 20 basic models. General descriptions are as follows.

Horizontal Pumps-Lined

Type AH

'AH' pumps are designed for a wide range of erosive and/or corrosive applications.

They are generally used for slurries containing high concentrations of erosive solids or where an extremely heavy duty pump is required.

All Warman standard seal options are available; centrifugal, gland or mechanical types to include the Warman full flush and low flow seal options.

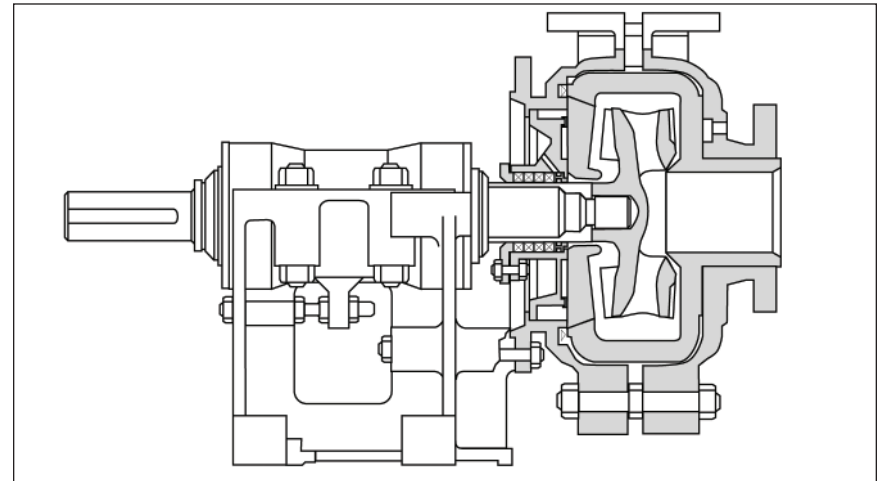

Figure 4-1 Type AH Pump

Pump discharge sizes range from 1 inch to 18 inches.

A range of alternative drive frames are available to accommodate widely varying power demand requirements.

Type GP

The Warman 'GP' series is specifically designed to handle a wide range of corrosive and erosive liquors and slurries. They are typically used in chemical applications or where slurries contain lower concentrations (up to 35% by weight) of erosive solids. The 'GP' can also be used for pumping higher concentrations of less erosive solids. Sealing options include centrifugal, gland and mechanical.

The 'GP' is somewhat smaller in size to the corresponding 'AH' model. This range features a high strength fiber reinforced resinous outer casing.

Sizes range from 30 mm (1.18 inches) to 200 mm (8.0 inches) discharge.

The GP features interchangeable bearing frames with most other Warman models.

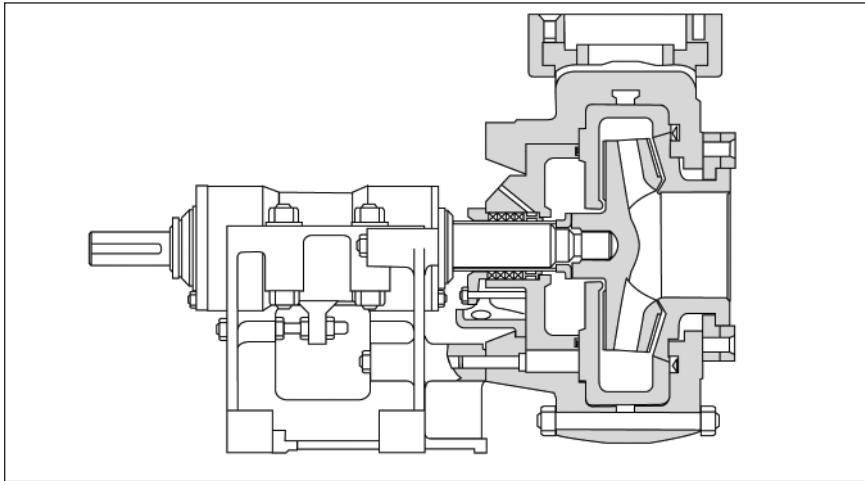

Figure 4-2 Type GP Pump

Type L

'L' pumps are designed essentially for the same range of applications covered by the 'GP' series, but cover much higher flow ranges with discharge sizes extending up to 650 mm (28.0 inches).

Alternative drive frame sizes are available in all models to accommodate varying power demand requirements. As with the GP, bearing frames are interchangeable with most other Warman models. Standard Warman seal options are also available.

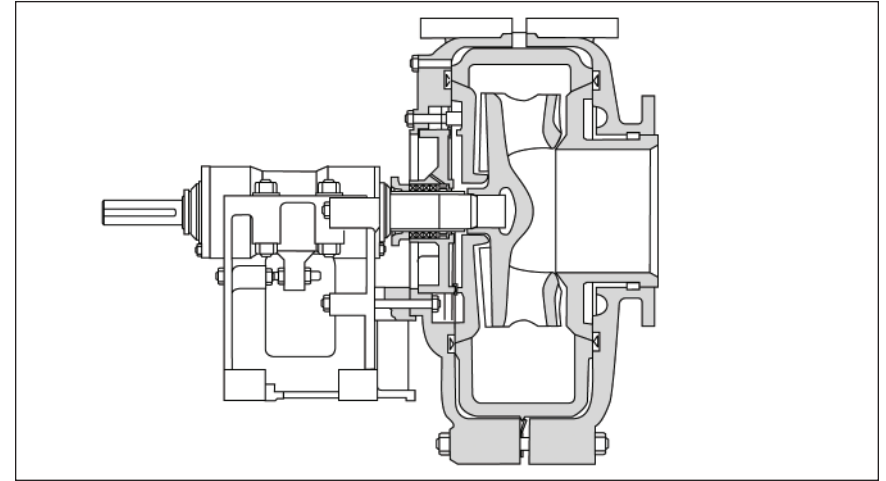

Figure 4-3 Type L Pump

Type AHP

'AHP' pumps have the same hydraulic performance as the Type 'AH' pumps and normally use the same liners and impellers. The same performance curves are also applicable. These pumps are used where high pressure ratings are required, usually in multi-stage pump installations and feature heavily reinforced outer casings to contain high internal pressures (up to 500 psi working pressure). (Higher ratings available in AHPP)

Type HRM

'HRM' pumps are characterized by computer designed hydraulics for those applications requiring high heads (up to 315 ft. per stage) and/or high discharge pressures. The 'HRM' is an evolution in pump hydraulics for extremely heavy duty applications.

All standard seal designs and material options are available, although impellers are generally restricted to metal alloys only.

Type W

'W' pumps consist of a Type 'AH' pump fitted with a tank between the pump base and the pump wet-end. The tank is filled with water which prevents air entering the pump through the gland when operating with negative suction heads. These pumps are mostly used on vacuum filtrate-extraction duty. The submerged gland seal precludes the use of non-return valves in high vacuum duties and maintains a water tight seal at all times.

Hydraulic performance of these pumps are identical to the corresponding Type 'AH' pumps. For example, the performance for a 3/2 C-AHW pump is the same as the 3/2 C-AH pump.

Discharge diameters range from 1 inch to 6 inches.

Type AHF/LF/MF

AHF/LF/MF pumps consist of the AH/L/M pumps fitted with a new cover plate, throatbush, and impeller to provide an enlarged suction N0336. This enlarged intake enhances the ability of this horizontal pump to handle frothy slurries successfully. The new impeller is of the semi-open design with specially designed vanes to positively feed the frothy mixture to be pumped. Discharge diameters range from 3 inches to 14 inches.

Horizontal Pumps-Unlined

Type AHU

The 'AHU' is the same pump hydraulically as the heavy duty 'AH' series except that it has a bowl instead of the fully lined casing design of the 'AH'. All other parts, drive end, performance and installation dimensions are the same as the 'AH' design.

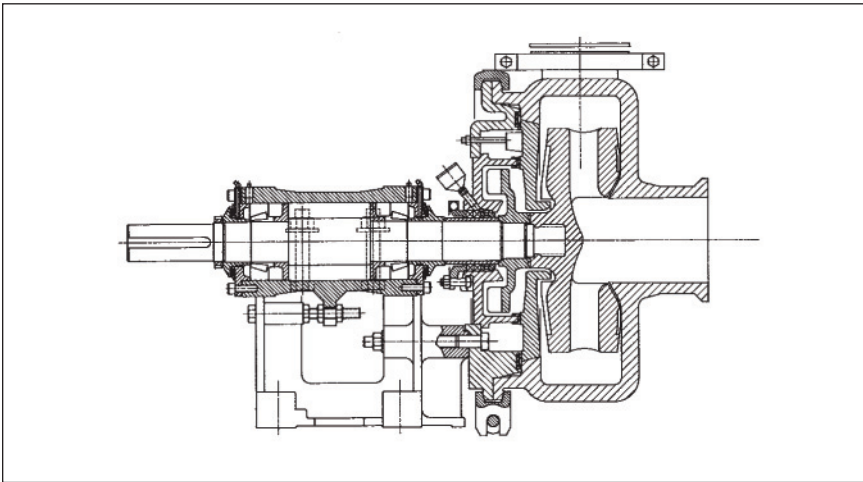

Figure 4-4 Type AHU Pump

Type D

'D' dredge pumps are designed for dredging and similar low head duties. The design features a hard metal casing and wear components and are capable of passing extremely large particles. Sizes range from 14 inches diameter discharge to 36 inches.

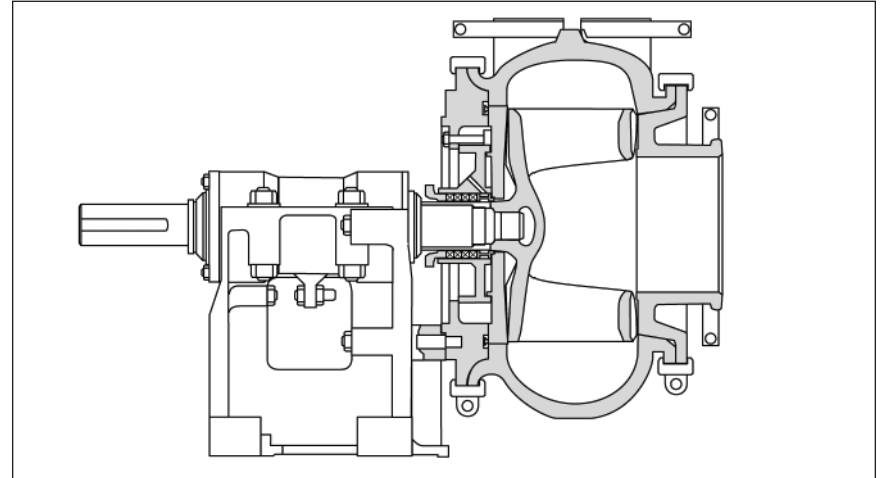

Figure 4-5 Type D Pump

Type G

Type 'G' gravel pumps are similar in design to the Type 'D' but feature larger impellers and heavier casing construction. They are typically used for pumping gravel, dredging or pumping solids too large to be handled by Type 'AH' pumps. Sizes range from 4 inches to 24 inches.

Type GH

The 'GH' range is again similar in construction to both the 'D' and 'G' Types, but features larger impeller diameters than the 'G' range and incorporates a heavily reinforced casing design to allow pumping of heads up to 260 ft. Typically used in dredging applications where long discharge distances are required.

The 'GH' is available in sizes ranging from 6 inches diameter discharge up to 16 inches.

Type TC/C

The CYKLO 'TC/C' Type is an uncased design available in erosion resistant materials designed specifically for "non clog" or "gentle" pumping applications.

The 'TC/C' range is available in sizes ranging from 2 inches diameter discharge up to 10 inches diameter discharge.

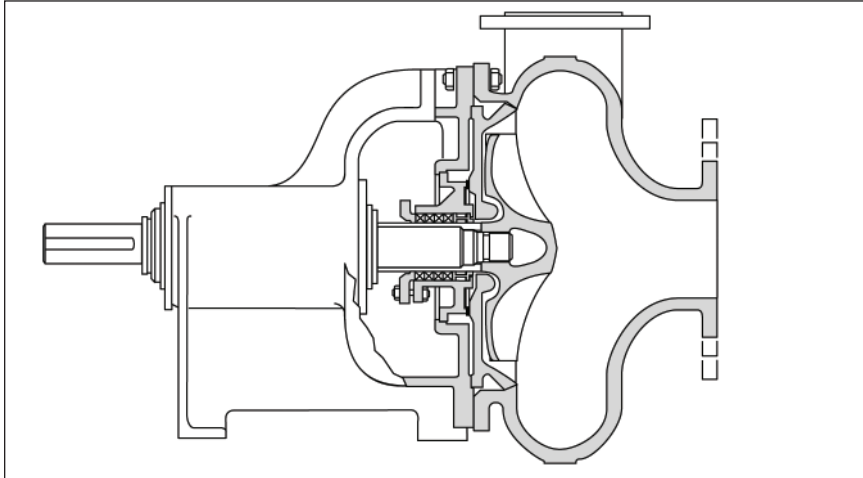

Figure 4-6 Type TC/C Pump

Type AHUC

The 'AHUC' pump is the AHU with the 'CYKLO' recessed impeller available in abrasion resistant white iron materials designed specifically for "non clog" or "gentle" pumping applications.

The 'AHUC' range is available in sizes ranging from 2 inch diameter discharge up to 4 inch diameter discharge.

Vertical Pumps

Type SP/SPR

The 'SP/SPR' range is of a vertical cantilevered design that features hard alloy wear parts or full elastomer protection on all submerged components. This allows this pump to be used in highly corrosive applications. Available in sizes 40 mm (1.5 inches) up to 250 mm (10 inches).

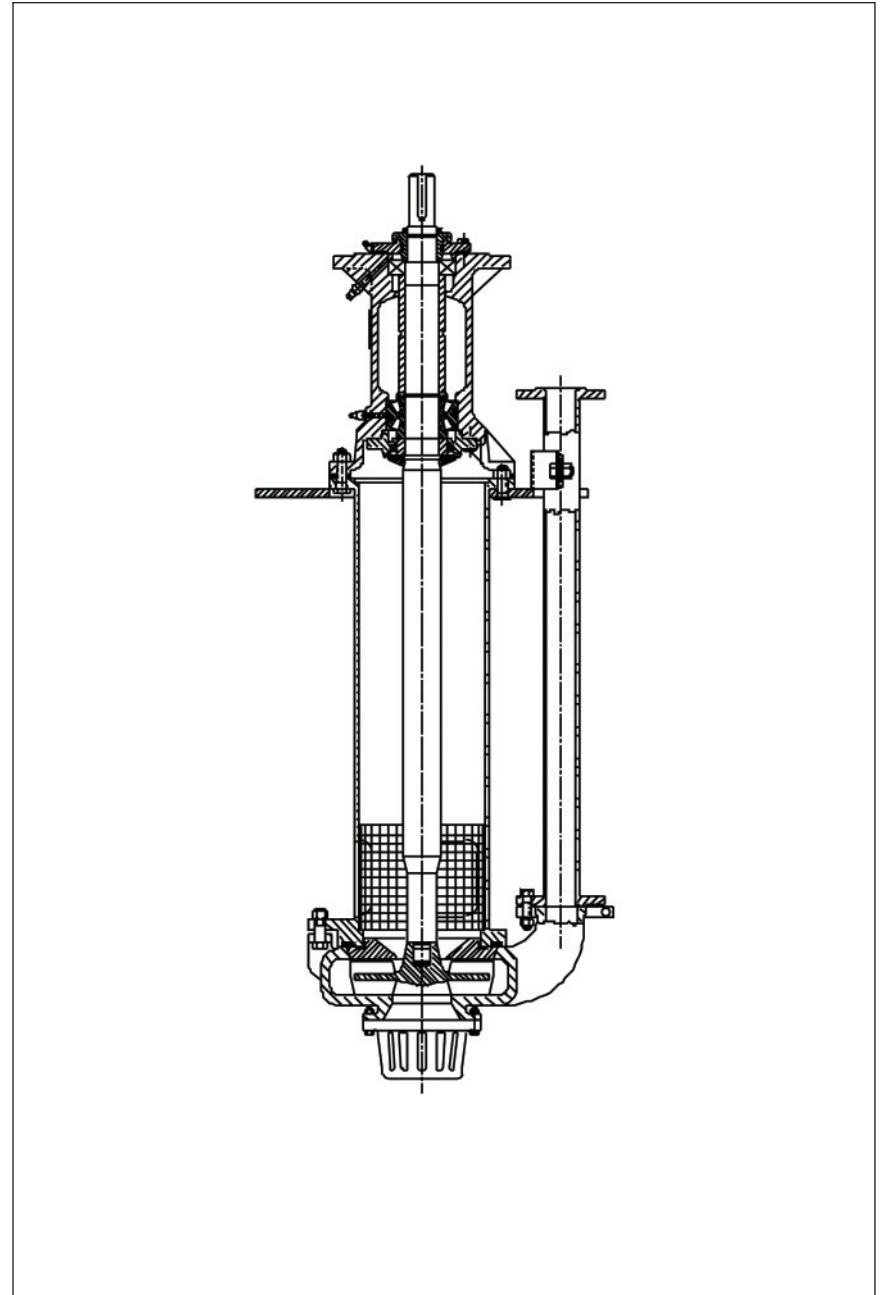

Figure 4-7 Type SP Pump

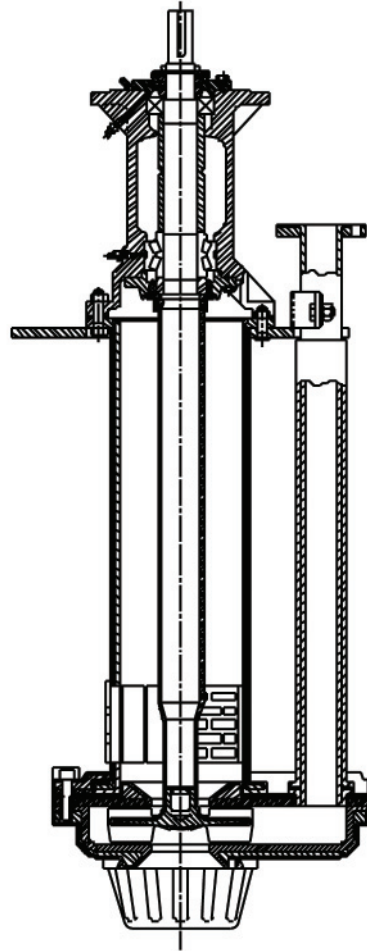

Figure 4-8 Type SPR Pump

Type HDSP Series AHU/C

These heavy duty sump pumps are suited for sumps with a high percentage of solids, such as mill discharge clean-up sumps, as well as process sumps with higher concentration of solids than allowed in the SP/SPR. It uses the unlined bowl design of the horizontal AHU and is also available with the 'CYKLO' recessed impeller where clogging may be a possibility. The length settings are shorter than the standard SP/SPR model sump pumps and are custom designed for specific applications.

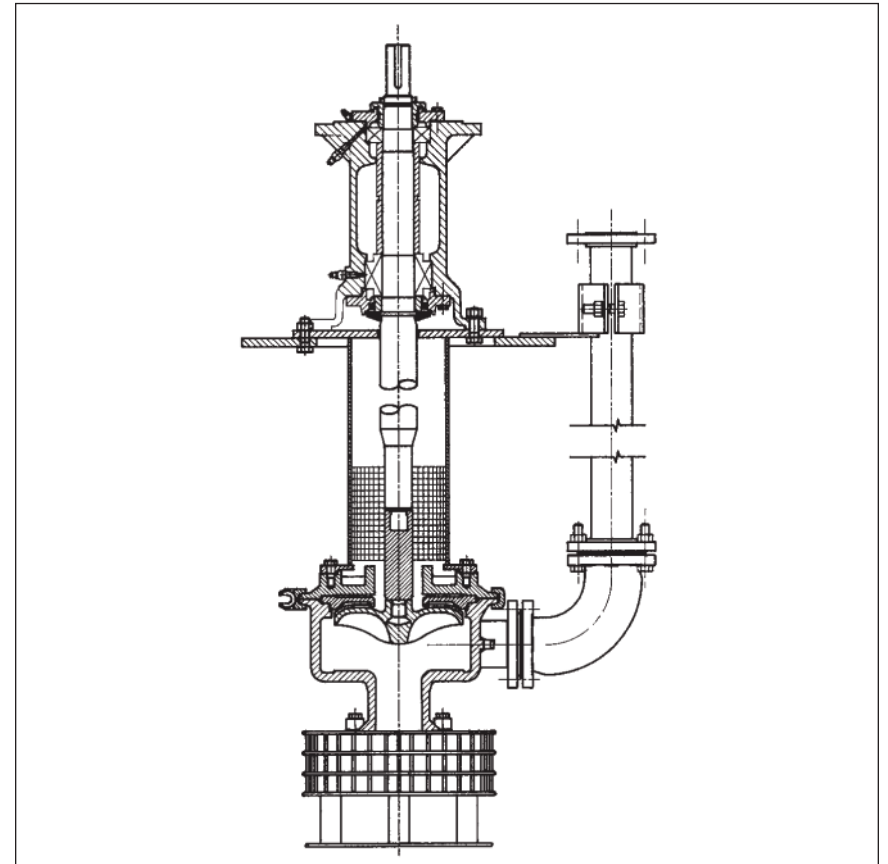

Figure 4-9 Type HDSP Series AHU/C Pump

Type V-TC

The 'V-TC' range is a combination of the Cyklo (TC) type hard metal wet end fitted to the vertical cantilevered shaft bearing assembly.

These pumps find application where non-clogging or "gentle" pumping features of the cyklo design are required in a vertical submerged situation.

Available in discharge diameters ranging from 2 inches to 10 inches.

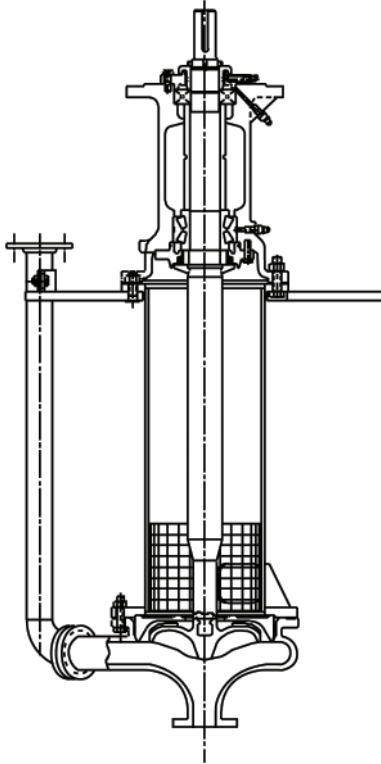

Figure 4-10 Type V-TC Pumps

Section 5 - Materials

Introduction

A major advantage of a Warman slurry pump is the number of optional materials available. This enables a pump to be constructed with the most appropriate materials specifically to meet the duty requirements. It also allows existing pumps to be adapted in service to meet changing duties, merely by changing individual parts.

A general description of some of the more common materials used in Warman slurry pump construction is listed in Table 5-1.

Further assistance with specific material selections can be obtained from your nearest Weir Minerals office.

Material Types and Data Descriptions

Warman Code	Material Name	Type
A03	Ni-Hard 1	Martensitic White Iron
.....		
A04	ULTRACHROME®	24% Cr Erosion Resistant White Iron
A05	ULTRACHROME®	27% Cr Erosion Resistant White Iron
A06	Ni Hard 4	Martensitic White Iron
A07	15/3 Chrome/Moly Iron	Chromium/Molybdenum
A12	HYPERCHROME®	30% Cr Hypereutectic Chromium White Iron
A25	Ni-Cr-Mo Steel	Cast Steel
A49	ULTRACHROME®	28% Cr, Low Carbon, High Chromium, Low C White Iron

Description
Alloy A03 is a martensitic white iron which offers reasonable performance in mildly erosive duties, and where low impact levels are experienced. It is generally heat treated to stress relieve or reduce the amount of residual austenite in the matrix. The alloy is sensitive to section thickness, and the composition requires adjustment to prevent the formation of undesirable phases.
Alloy A04 is a white iron having a hardness of 375 BHN in the annealed state. This low hardness allows A04 to be more readily machined than alloy A05. The alloy can be subsequently hardened to increase the wear resistance. A04 is not as erosive resistant as A05 and A12, and is not generally corrosion resistant.
Alloy A05 is a wear resistant white iron that offers excellent performance under erosive conditions. The alloy can be effectively used in a wide range of slurry types. The high wear resistance of alloy A05 is provided by the presence of hard carbides within its microstructure. Alloy A05 is particularly suited to applications where mild corrosion resistance, as well as erosion resistance is required.
Martensic wear resistant alloy
Martensic white iron with moderate erosion resistance
HYPERCHROME® alloy is a hypereutectic white iron suitable for high wear duties, where corrosion is not considered a problem. It should be used in applications where A05 and A03 do not provide an adequate wear life. Alloy A12 can be used in mild alkaline slurries, between a pH range of 8 to 14. The alloy may provide up to three times the wear life of A05 and A03 parts in some severe applications.
Alloy A25 is an alloy steel having moderate wear resistance and high mechanical properties. The alloy is used for large castings where toughness is of primary importance.
Alloy A49 is a corrosion resistant white iron suitable for low pH corrosion duties, where erosive wear is also a problem. The alloy is particularly suitable for Flue Gas Desulfurization (FGD) and other corrosive applications, where the pH is less than 4. The alloy can also be used in other mildly acidic environments. A49 has an erosion resistance similar to that of Ni-Hard 1.

MATERIAL TYPES AND DATA DESCRIPTIONS (continued)

Warman Code	Material Name	Type
A51	ULTRACHROME®	36% Cr, Erosion/Corrosion White Iron, Low C
C02	Ni-Resist (Copper free)	Corrosion Resistant Cast Iron
C21	13% Chromium Steel	Martensitic Stainless Steel
C23	Type 316 Stainless Steel	Austenitic Stainless Steel
C25	Alloy 20	Austenitic Stainless Steel
C26	26 Cr 5 Ni Stainless Steel (CD-4M Cu)	Duplex Stainless Steel
C27	'825' Alloy	Austenitic Corrosion Resistant Alloy
C30	27 Cr 31 Ni Stainless Steel	Austenitic Stainless Steel
C44	Type 440C Stainless Steel	Hardenable Stainless Steel
C55	Ferralium 255	Duplex Austenitic/Ferritic Stainless Steel
D21	Ductile Grey Iron (SG Iron)	Cast Iron
G01	Cast Iron	Cast Iron
N02	63 Ni 30 Cu Alloy	Corrosion Resistant Alloy
N04	58 Ni 16 Cr 16 Mo Alloy	Corrosion Resistant Alloy
N05	55 Ni 22 Mo Alloy	Corrosion Resistant Alloy
J21	Tungsten Carbide Coated 420SS	Ceramic Coated Stainless Steel

Description
ULTRACHROME® A51 is a premium erosion/corrosion alloy to be used where excellent erosion and corrosion resistance is required. The alloy has much improved corrosion resistance compared to alloy A49, while the erosion resistance is similar to Ni-Hard type alloy irons. The alloy is suitable for phosphoric acid duties, FGD duties, sulphuric acid and other moderately corrosive applications.
Alloy D21 is a ductile grade of grey iron used where higher physical properties and greater shock resistance are required compared to G01.
Standard grey iron
J21 is a ceramic coating, (V21) applied over a C21 substrate. The combination of these two materials provides high abrasive wear resistance together with high toughness. The tungsten carbide layer is deposited onto the C21 substrate using a special spray technique which yields minimal porosity and excellent interlayer adhesion. J21 is unaffected by differential thermal expansion and will not "spall".

MATERIAL TYPES AND DATA DESCRIPTIONS (continued)

Warman Code	Material Name	Type
J24	Tungsten Carbide Coated 316SS	Ceramic Coated Stainless Steel
J26	Chrome Oxide Coated CD4-MCu	Ceramic Coated Duplex Stainless
J27	Tungsten Carbide Coated CD4-MCu	Ceramic Coated Duplex Stainless
P50	Polyphenylene Sulphide (Ryton*)	Reinforced Structural Polymer
P60	UHMW Polyethylene	Engineering Polymer
R08	Standard Impeller Rubber	Natural Rubber
R24	Anti Thermal Breakdown Rubber	Natural Rubber
R26	Standard Liner Rubber	Natural Rubber
R33	Natural Rubber (Soft)	Natural Rubber
S01	EPDM Rubber	Synthetic Elastomer
S12	Nitrile Rubber	Synthetic Rubber

Description
Standard option for longer sleeve wear, but adds additional corrosion resistance.
Standard option for longer sleeve wear, but adds additional corrosion resistance.
Standard option for longer sleeve wear, but adds additional corrosion resistance.
P50 is a high-strength plastic suitable for parts requiring high-dimensional stability.
R08 is a black natural rubber, of low to medium hardness. R08 is used for impellers where superior erosive resistance is required in fine particle slurries. The hardness of R08 makes it more resistant to both chunking wear and dilation (i.e.: expansion caused by centrifugal forces) as compared to R26. R08 is generally only used for impellers.
Anti Thermal Breakdown Rubber (ATB) is a soft natural rubber based on R26, but with improved thermal conductivity. It is intended for use as a liner material in slurry pumping applications where high impeller peripheral speeds are required.
R26 is a black, soft natural rubber. It has superior erosion resistance to all other materials in fine particle slurry applications. The antioxidants and antidegradents used in R26 have been optimized to improve storage life and reduce degradation during use. The high erosion resistance of R26 is provided by the combination of its high resilience, high tensile strength and low Shore hardness.
R33 is a premium grade black natural rubber of low hardness and is used for cyclone and pump liners and impellers where its superior physical properties give increased cut resistance to hard, sharp slurries.
Elastomer S12 is a synthetic rubber which is generally used in applications involving fats, oils and waxes. S12 has moderate erosion resistance.

MATERIAL TYPES AND DATA DESCRIPTIONS (continued)

Warman Code	Material Name	Type
S31	Chlorosulfonated Polyethylene (Hypalon®*)	Synthetic Elastomer (CSM)
S42	Polychloroprene (Neoprene®*)	Synthetic Elastomer (CR)
S45	High Temperature Hydrocarbon Resistant Rubber	Synthetic Elastomer
S51	Fluoroelastomer (Viton®*)	Synthetic Elastomer
U01	Wear Resistant Polyurethane	Polyurethane Elastomer
Y07	Alumina 99%	Ceramic
Y08	Silicon Nitride Bonded Silicon Carbide	Ceramic

* Hypalon, Neoprene and Viton are registered trademarks of the Dupont Company

Description
S31 is an oxidation and heat resistant elastomer. It has a good balance of chemical resistance to both acids and hydrocarbons.
Polychloroprene (Neoprene) is a high strength synthetic elastomer with dynamic properties only slightly inferior to natural rubber. It is less effected by temperature than natural rubber, and has excellent weathering and ozone resistance. It also exhibits excellent oil resistance.
S45 is an erosion resistant synthetic rubber with excellent chemical resistance to hydrocarbons at elevated temperatures.
S51 has exceptional resistance to oils and chemicals at elevated temperatures. Limited erosion resistance.
U01 is an erosion resistant material that performs well in elastomer applications where 'tramp' is a problem. This is attributed to the high tear and tensile strength of U01. However, its general erosion resistance is inferior to that of natural rubber (R26, R08).
Wear resistant ceramic
Wear resistant ceramic

Section 6 - Friction Data

Introduction

Despite the long history of successful slurry pumping operations covering a wide range of slurries, limited published data is available to estimate H_f accurately for every possible duty. A high degree of accuracy is normally required only if H_f represents a high proportion of the Total Dynamic Head, H , for a proposed application so that large errors in estimating H_f would be reflected in correspondingly large errors in estimating H .

This normally applies to very long-distance pumping duties only. For most Warman Pump applications, a high degree of accuracy in estimating H_f is not required.

Homogeneous Slurries

In homogeneous slurries, all of the particles are essentially finer than 50 microns (μm). At sufficiently low concentrations, H_f will be close to that for clear water and may be estimated by the same empirical method as applied to Category 'A' Heterogeneous Slurries.

At sufficiently high concentrations, the Yield Stress characteristic largely influences the value of H_f . For further information on pumping homogeneous slurries with high concentrations, contact your nearest Warman representative.

Heterogeneous Slurries

Category 'A': Particles are essentially all coarser than 50 μm and finer than 300 μm and with C_w from ZERO to 40%. Typical friction head loss curves for this category are illustrated in Figure 6-1.

Analyses of H_f data on these slurries indicates that, for any given solids concentration, the slurry H_f is numerically higher than the water H_f for velocities below approximately $1.30 V_L$. However, the H_f value does not fall below a minimum at lower velocities, due to the effect of solids which settle in the pipe. This minimum occurs at approximately $0.70 V_L$, where the slurry H_f is approximately equal to the H_f for water at V_L .

The empirical data are summarized:

At $1.30 V_L$ (approximately):

Slurry H_f is numerically equal to water H_f .

At $0.70 V_L$ (approximately):

Slurry H_f is at its minimum value.

Slurry H_f is numerically equal to the H_f for water at V_L .

The most economical slurry velocity is a velocity slightly in excess of V_L , thus these empirical relationships allow the construction of the useful portion of the estimated slurry H_f curve, in relation to the water H_f curve, for the same pipe.

Consequently, a reliable method of estimating H_f for water should be adopted when estimating a Category 'A' Slurry H_f .

NOTE: Both water H_f (head of water) and slurry H_f (head of mixture) should each be expressed in head of actual "mixture" pumped.

Figure 6-1 also illustrates the construction of the estimated slurry H_f curves, based upon the estimated water H_f curve. Each slurry H_f curve meets tangentially with the water H_f curve where the value of V_L corresponds to $1.30 V_L$.

It is emphasized that this empirical method of estimating H_f for these Category 'A' slurries is not precise but, in the absence of pipeline test rig data on the particular slurry or other more reliable data, it provides estimates considered to be reasonably accurate for many practical slurry pumping applications.

Category 'B': Particles are essentially all coarser than $50 \mu\text{m}$ and finer than $300 \mu\text{m}$ but with C_w greater than 40%.

Generally, friction head losses for this category are much higher than for Category 'A' due largely to the increased friction effect of the more closely-packed solids content upon the pipewall. This effect generally increases with increasing C_w and is so greatly influenced by a number of variables, for example, C_w , S , S_r , d_{50} , and actual sieve analysis of solids present that it is not possible to provide a simple empirical method for estimating slurry H_f .

In general, slurry H_f values may vary over a range, commencing with values approximately equal to those applicable to Category 'A' slurries at $C_w = 40\%$, to values up to double or more those of Category 'A' slurries, for velocities in excess of V_L .

Consequently, H_f values for Category 'B' slurries must often be estimated, then adjusted by an "experience factor". The H_f values are first estimated as if for Category 'A', after allowing for the lower values of F_L (and V_L) associated with values of C_w in excess of $C_w = 30\%$, see Figure 6-1.

The true values of H_f may be double or more than the estimated values. This is allowed for by providing reserves of speed and power for values of H_f up to double, or more, of the values estimated for H_f . While this introduces the risk of large error in the estimation of H_f , the effective overall error in estimating Total Dynamic Head (H) is relatively small, if the other component of H (for example, Z , H_{pf} and H_{ve}), when combined, represent the major portion of H.

Should the value of H be estimated with a relatively small error, the effect would probably be almost insignificant.

For example, it would simply result in a slightly higher or lower value of Z_s in the sump and/or a correspondingly slightly higher or lower power consumption. Should the error be more significant, with obvious overspeed or underspeed, the

pump speed may be adjusted, for example, by changing the motor pulley or via a variable speed control, if provided. In either case, the drive motor should be adequately rated.

NOTE: Some test work results for slurry containing heavy solids ($S = 4.67$ to 5.3) of approximately $150 \mu\text{m}$ sizing has shown a trend towards decreasing head loss with increasing solids concentration, between $C_v = 10\%$ and $C_v = 25\%$ (that is, C_w between approximately 40% and 60%).

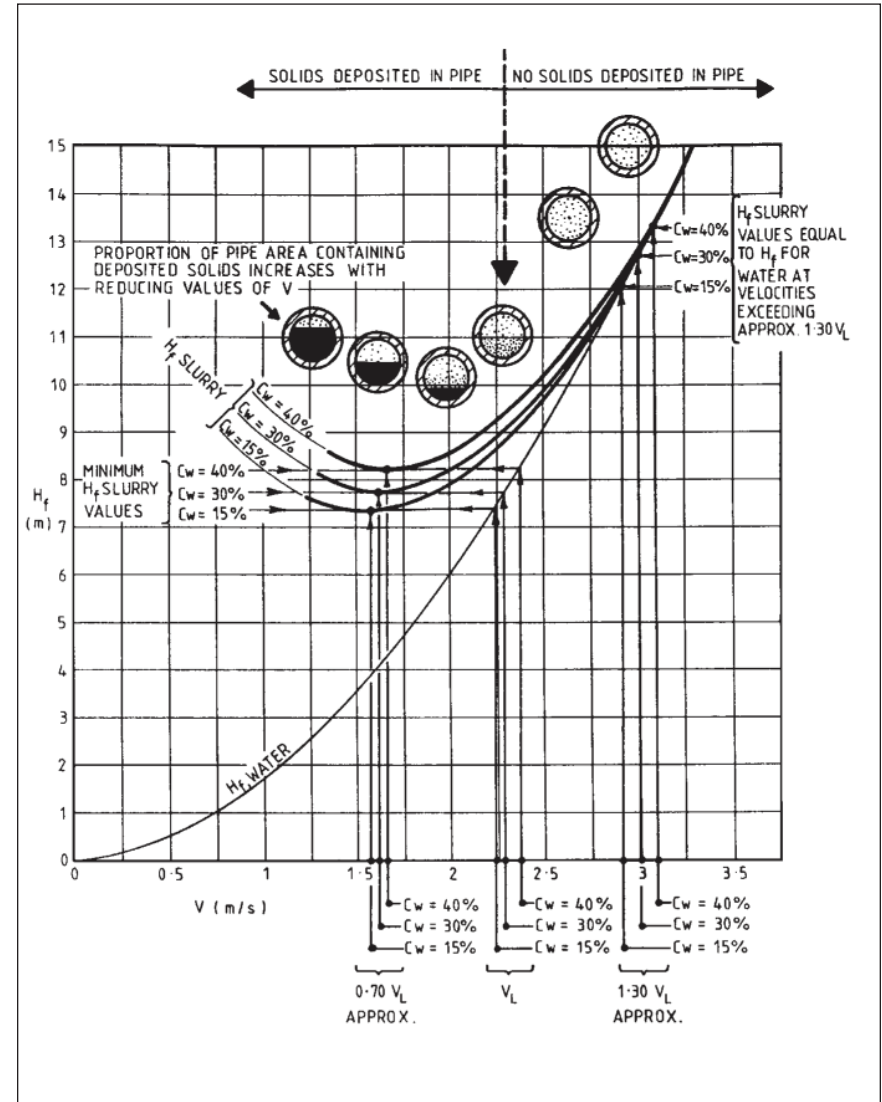

Figure 6-1 Typical H_f Curve For Category 'A' Slurries

Many Warman pumps are used in heavy-duty, Category 'B' slurry applications.

Typical examples include the following:

- Mill Discharge Plant,
- Thickener Underflow,
- Sand Tailings Stacking, and
- Gravity Concentrator Feed.

Category 'C': Particles essentially coarser than 300 µm and C_w from ZERO to 20%.

Generally, friction head losses for Category 'C' slurries are also much higher than for Category 'A'.

The more common applications for Warman pumps on Category 'C' slurries are the suction dredging of gravel and/or coarse sand. In normal dredging operations, C_w is often less than 20%, due to the impracticality of continuously entraining such coarse particles at the intake of the suction pipe at a higher value of C_w .

H_f for these slurries is estimated on the basis of the minimum average velocity FOR DESIGN being no less than V_L when $F_L = 1.4$.

For V_L and for velocities greater than V_L - slurry H_f is taken to be numerically equal to 1.10 H_f for water, that is, numerically 10% higher than the estimated water H_f .

Category 'D': Particles essentially coarser than 300 µm and C_w greater than 20%.

Generally, friction head losses for Category 'D' slurries are higher than for Category 'A'. The values of H_f may be first estimated by the same method as for Category 'A'. However, the true slurry H_f may vary from values close to those for Category 'A' up to three times or more those of Category 'A' slurries, (for velocities in excess of V_L). Consequently, reserves of speed and power should be provided.

Estimation of Friction Head Losses For Clear Water

The recommended method for estimating H_f for clear water is by using Darcy's formula as follows:

H_f	=	$f \times L/D \times V^2/2g$
Where,	H_f	Friction Loss (ft)
	L	Total Equivalent Length of pipe (ft)
	D	Inside diameter of pipe (ft)
	f	Darcy Friction Factor
	V	Velocity (ft/s)
	g	Gravitational Acceleration (32.2 ft/s ²)

Use the Warman Pipe Friction Chart, Figure 6-2, to evaluate the Darcy Friction Factor, f.

* NOTE: For convenience, this chart is entered at values of Inside Diameter of Pipe: "d", expressed in inches.

The application of Darcy's formula, in combination with the Warman Pipe Friction Chart, is the recommended method of estimating H_f for water. This information should then be used for construction of the System Resistance Curves for clear water and Category 'A' slurries (by the empirical method) illustrated in Figure 6-1.

1. Advantages of this Procedure

a. The Warman Pipe Friction Chart provides the Darcy Friction Factor (and thus H_f) values for clear water based on the most reliable data available to the date of this publication. This data takes into account the maintenance of certain values for Relative Pipe Wall Roughness, k/d, due to the continuous 'polishing' action of abrasive slurries flowing through the pipes.

For example, on Figure 6-2, the values of k/d for 'commercial steel' pipes are the same as the values for 'cement' and 'polyethylene' pipes. However, when these pipes are used for handling non-abrasive liquids only, such as clear water, the true values of k/d for steel pipes would be actually a little higher, yielding correspondingly higher values of H_f for water.

b. The empirical method for the construction of the estimated System Resistance Curve for water, and the subsequent construction of the System Resistance Curve for slurry, allows for the varying degrees of difference between H_f for water and H_f for slurries. This is particularly the case in the range of flow rate between V_L to 1.30 V_L , which is the usual range of most interest.

2. Example of Friction Head Loss Estimation for Water

Given L = 2300 ft of commercial steel pipe

d = 8 inch (i.e.: D = .66 ft), see Figure 6-3.

Q = 1500 GPM

g = 32.2 ft/sec²

3. Calculations

$$V = \frac{Q \times .4085}{d^2} = \frac{1500 \times .4085}{d^2} = 9.57 \text{ ft/sec}$$

Refer to the Warman Pipe Friction Chart, Figure 6-2.

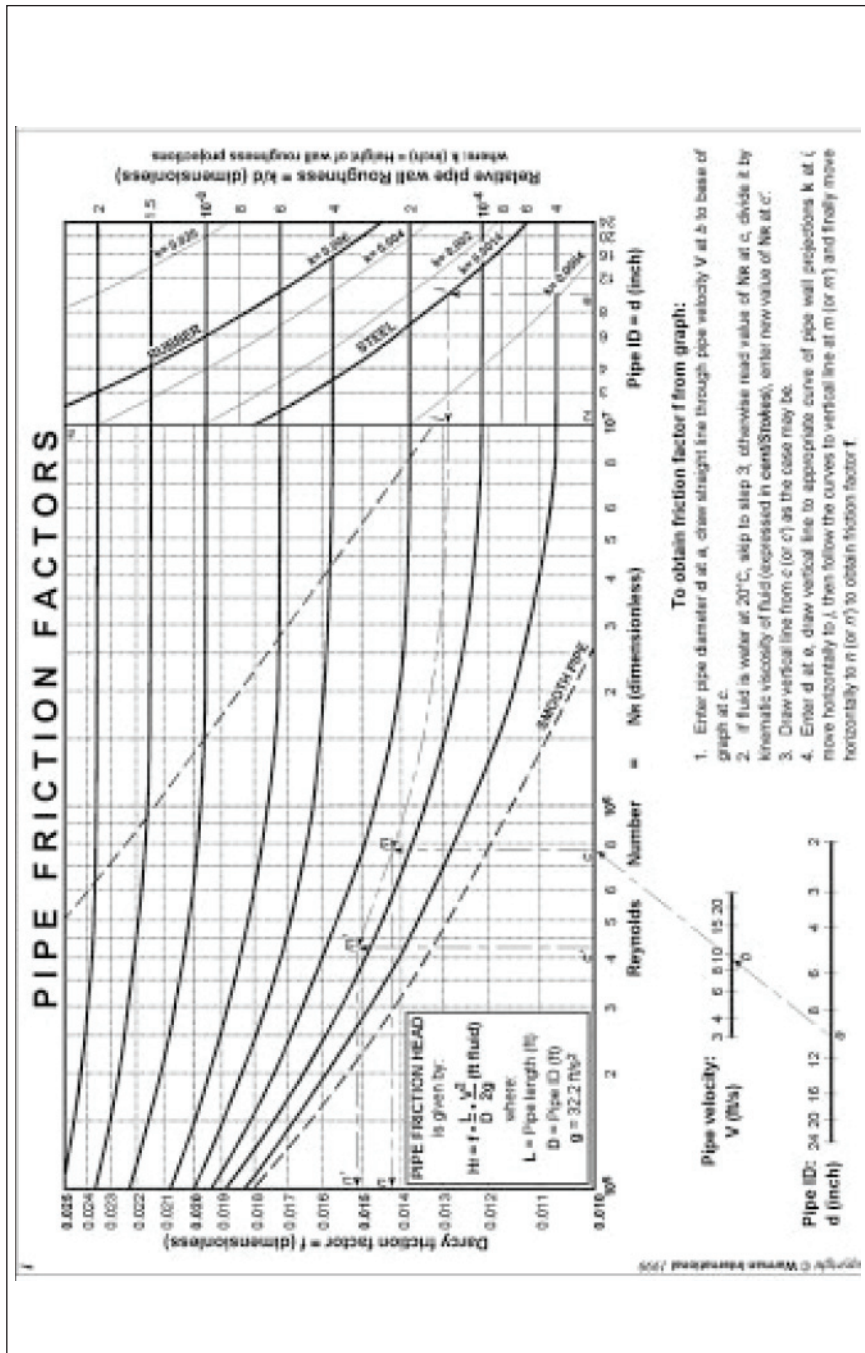

Figure 6-2 Warman Pipe Friction Chart

As illustrated with arrowed lines, the chart is entered at the right hand bottom scale, along the applicable 'd' coordinate and, at its intersection with the appropriate ('pipe surface material') reference line, the corresponding 'k/d' coordinate is followed across, towards the left hand portion of the chart, until it intersects the *NR = 10⁷ coordinate. From this intersection, the 'k/d' coordinate is drawn as a curve following the geometry of the adjacent family of curves.

(* Reynolds Number (NR) is an expression for the ratio of inertia forces to viscous forces.)

The left hand portion of the chart is entered separately via a line drawn across the nomogram axes 'd' and 'V' at their applicable values, to intersect the bottom (Reynolds Number) axis of the chart. (Actual values of NR are also shown at the top of the chart). A vertical line is then drawn to intersect the curve drawn previously and a horizontal line is finally drawn to intersect the left (Friction Factor) axis.

For the example shown:

$$f = 0.0158$$

Thus the value of friction loss, H_f can be evaluated as follows:

$$H_f = f \times \frac{L}{D} \times \frac{V^2}{2g}$$

$$H_f = 0.0158 \times \frac{2300}{.66} \times \frac{9.57^2}{2 \times 32.2} = 78.3 \text{ ft}$$

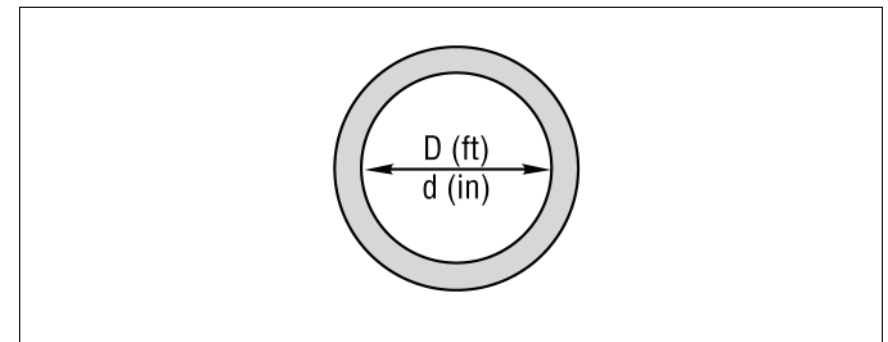

Figure 6-3 Pipe Diameter

Section 7 - Total Dynamic Head

Introduction / Abstract

The main components of Total Dynamic Head are:

- Total Discharge Head, and
- Total Suction Head.

The equation is,

Total Dynamic Head = Total Discharge Head - Total Suction Head.

Algebraically, $H = (H_d) - (H_s)$

or, $H = (H_{gd} + H_{vd}) - (H_{gs} + H_{vs})$

The values H_{vd} and H_{vs} are always positive (+ve)

H_d is usually positive (+ve), (above pump centerline)

H_s may be positive (+ve), (above pump centerline) or negative (-ve), (below pump centerline)

When H_s is positive (+ve): $H = (H_d) - (H_s)$ ie: $H = H_d - H_s$

When H_s is negative (-ve): $H = (H_d) - (H_s)$ ie: $H = H_d + H_s$

Total Discharge Head, H_d

Basic Simple Formula:

$$H_d = Z_d + H_{fd} + H_{ve}$$

Z_d may be positive (+ve) or negative (-ve)

If applicable, additional terms must be included in the formula to account for increased value of H_d , due to any contractions (for example, nozzle friction loss) and enlargements; friction loss in a flow-measuring device and exit into pressure-fed equipment, for example, a hydraulic cyclone.

Total Suction Head, H_s

Basic Simple Formula: $(H_s) = (Z_s) - H_i - H_{fs}$

(H_s) and (Z_s) may each be positive, (+_{ve}) or negative, (-_{ve}).

If applicable, additional or substitute terms must be included in the formula to account for increased or decreased values of H_s due to any contractions, enlargements, flow measuring device. These are as follows:

- liquid supply surface being under pressure, H_{pr} or under vacuum, H_{vac}
- differential column head loss, Z_c and
- substitution of effective mixture static suction head Z_{sm} in lieu of Z_s .

NOTE: Values of H_s are directly applicable in $NPSH_a$ calculations and in selection of shaft-sealing arrangements.

Relationships Between Head, Specific Gravity & Pressure, or Vacuum

The term “Total Dynamic Head” correctly describes the kinetic force developed by a centrifugal pump regardless of the specific gravity of the liquid or slurry pumped. The head (+_{ve}) or (-_{ve}) at any point in the system may be converted to pressure or vacuum, respectively, by the application of conversion formula.

Total Dynamic Head

Total Dynamic Head, H, is the head which is required by a given system to maintain a given flow rate, Q, through the system.

H varies as the flow rate through the system, Q, varies. The relationship of H with Q is known as the System Resistance and may be expressed algebraically or graphically.

Total Dynamic Head: With Positive (+_{ve}) Suction Head

Figure 7-1 illustrates a pump discharging a flow rate, Q, with discharge and suction gauge pressure heads, both relative to atmosphere and both corrected to pump centerline, measured at the pumps discharge flange and at the pump suction flange, respectively. All heads are expressed in feet of actual mixture being pumped.

The Total Dynamic Head, H, required to maintain flow rate ,Q, through the system is the algebraic difference between the Total Discharge Head and the Total Suction Head,

$$\begin{aligned}
 H &= H_d - (H_s) \\
 &= (H_{gd} + H_{vd}) - (H_{gs} + H_{vs}) \\
 \text{where } H_{vd} &= \frac{Vd^2}{2g} \text{ and } H_{vs} = \frac{Vs^2}{2g}
 \end{aligned}$$

These velocities represent the actual values for average velocity at the pump discharge flange (V_d), and at the pump suction flange, (V_s), respectively.

Total Dynamic Head: With Negative (-ve) Suction Head

When H_s is negative (-_{ve}), that is, a vacuum head is indicated by the gauge, as in Figure 7-2, the substitution of the negative value in the formula serves to positively increase the value of H with respect to H_d .

Estimation of Total Dynamic Head

As $H = (H_d) - (H_s)$ and as the suction and discharge pipes are often of different internal diameter, it is advisable to estimate values of H_d and H_s separately. The formula used should be the Basic Simple Formula, but amended where necessary to allow for any additional or substitute terms specific to the proposed duty as follows:

Total Discharge Head: H_d

Basic Simple Formula: $H_d = (Z_d) + H_{fd} + H_{ve}$

Typical Possible Additional Terms are as follows:

- Head Loss on conical enlargement, (see Figure 7-4).
- Head Loss on contraction, (see Figure 7-4).
- Head Loss on Exit into Pressure-Fed Equipment, (refer to Section 2).

Total Suction Head: H_s

Basic Simple Formula: $H_s = (Z_s) + H_i + H_{fs}$

Typical Possible Additional Terms are as follows:

- Head Gain in supply from Pressure Vessel, H_{pr} .
- Head Loss in supply from Vacuum Vessel, H_{vac} .
- Head Loss in Differential Column. (Applicable in dredge applications), Z_c (refer to #5 following)

Separate Estimates of Suction Head and Discharge Head

Pipeline Friction Head Loss, H_f

The friction head loss in a given pipeline is estimated for the Total Equivalent Length of Pipe, L (ft.), which is the sum of the Total Actual Length of Pipe, L_a (ft.) and the Aggregate of Equivalent Lengths for all valves, bends and like fittings, L_r (ft.), (see Figure 7-3) contributing to friction head loss in the pipeline.

$$\text{Generally } L = L_a + L_r$$

Specifically:

- for Suction Side: $L_s = L_{as} + L_{fs}$ (Friction Head Loss = H_{fs})
- for Discharge Side: $L_d = L_{ad} + L_{fd}$ (Friction Head Loss = H_{fd})

Values of H_{fs} and H_{fd} should be estimated separately, for example, during the preparation of the respective separate sets of calculations leading to the estimates of H_s and H_d . By separately estimating H_v , its value is readily available for use in NPSHa CALCULATIONS, (refer to Section 9, and in the selection of Shaft-Sealing arrangements, (refer to Section 2).

Inlet Head Loss, H_i ; Exit Velocity Head Loss, H_{ve} .

Separate provision is always made in the standard formula for the terms:

- H_i , the Inlet Head Loss (Suction side only), and

- H_{ve} , the Exit Velocity Head Loss (Discharge side only).

That is, the terms H_i and H_{ve} are included in the standard formula for H_s and H_d respectively.

Head Losses due to Contractions and Enlargements

These additional head losses are calculated by use of the formula provided in Figure 7-4. As no separate provisions are made in the standard H_s and H_d formula for individual symbols or terms anticipating these friction head losses, any such estimated head losses, if applicable, should properly be added to the values calculated for H_{fs} or H_{fd} respectively.

Friction losses in jet nozzles (H_{fn}) may be treated as conical contractions unless more reliable head loss data is available.

Several Additional Causes of Effects on H_{fs} or H_{fd}

The calculated values for H_{fs} and H_{fd} must be corrected to allow for permanent friction head losses when any in-line restrictions, such as flow-measuring devices, are intended to be installed (for example, quarter-circle orifice plates).

Differential Column Head Loss

Figure 7-5 depicts a mixture of Specific Gravity, S_m , flowing upwards and drawn from a supply of settled solids and overlying liquid, S_l . As the S_m is greater than S_l , the vertical height Z_v of mixture in the submerged portion of the suction pipe is not completely balanced by the surrounding liquid of the same vertical height, Z_l . The resulting effective static head loss is known as the Differential Column Head loss, Z_c :

$$\text{where } Z_c = Z_l \times \frac{(S_m - S_l)}{S_m} \text{ (ft)}$$

Where this condition exists, Z_c must be included as an additional head loss in the pipe system. This would affect both total head and NPSHa (refer to Section 9).

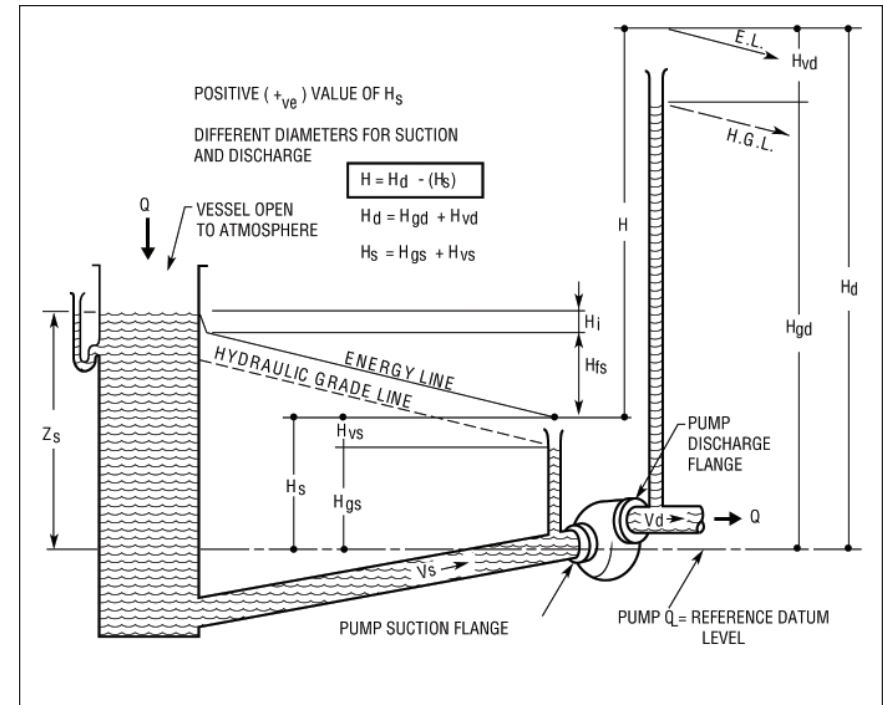

Figure 7-1 Total Dynamic Head With Positive Intake Head

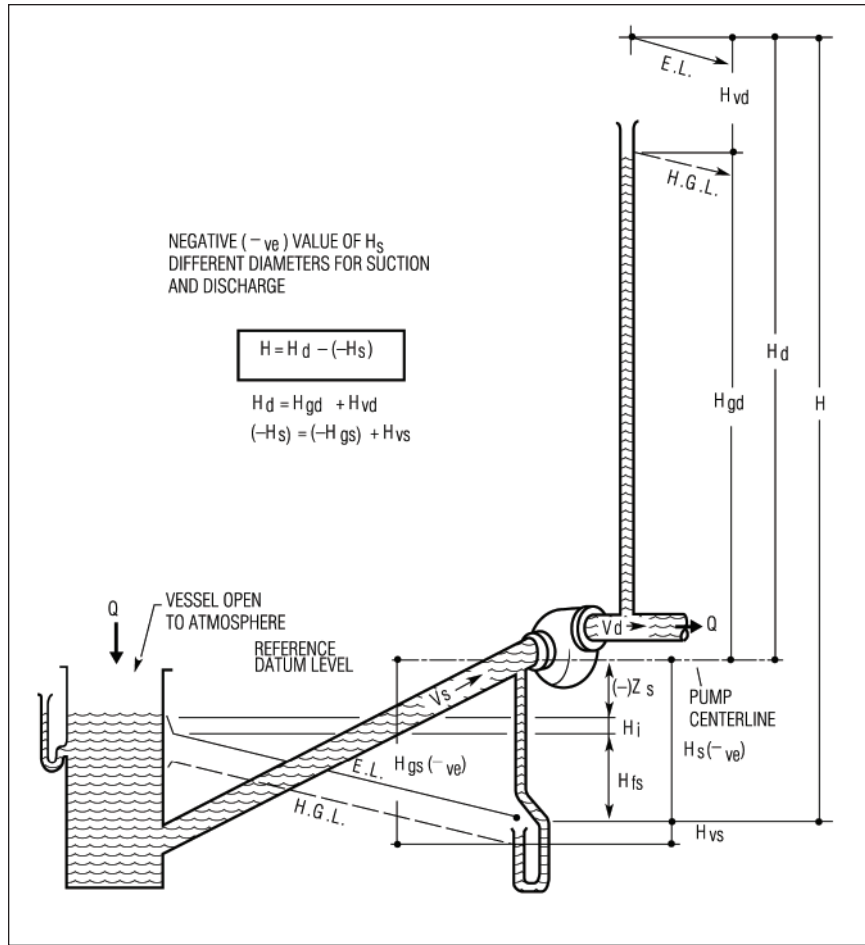

Figure 7-2 Total Dynamic Head with Negative Intake Head

INTERNAL DIAMETER Inches (Nom.)	90° Long Radius Bend Radius More Than 3 x N.B.	90° Short Radius Bend Radius is 2 x N.B.	Elbow	Tee	Rubber Hose Minimum Radius 10 x N.B.	Diaphragm Valve Full Open	Full Bore Valve Round Way	Plug-Lub Valve Rect. Way	*Tech- Taylor* Valve * Ball Type
1"	1.7	2.3	2.7	5.8	1.0	8.4	—	1.2	—
1-1/4"	2.4	3.0	3.7	7.8	1.3	10.8	—	1.6	—
1-1/2"	2.8	3.6	4.3	9.0	1.6	11.3	3.9	1.9	—
2"	3.5	4.6	5.5	11.0	1.8	12.0	4.7	2.4	—
2-1/2"	4.2	5.4	6.5	14.0	2.3	15.1	5.0	2.8	—
3"	5.1	6.8	8.1	17.0	2.8	16.0	6.3	3.4	0.86
3-1/2"	6.0	8.0	9.5	19.0	3.3	—	—	4.0	—
4"	7.0	9.1	11.0	22.0	3.8	25.0	7.2	4.6	0.77
4-1/2"	7.9	10.0	12.0	24.0	4.2	—	—	5.2	—
5"	8.9	12.0	14.0	27.0	4.7	43.0	10.0	5.8	1.0
6"	11.0	14.0	16.0	33.0	5.1	60.0	10.2	7.0	1.2
8"	14.0	18.0	21.0	43.0	7.9	65.0	26.0	9.0	2.7
10"	17.0	22.0	26.0	56.0	9.8	70.0	35.0	11.4	2.0
12"	20.0	26.0	32.0	66.0	11.0	95.0	52.0	13.4	2.5
14"	23.0	31.0	36.0	76.0	14.0	95.0	—	16.0	3.0
16"	27.0	35.0	42.0	87.0	16.0	—	—	18.0	3.4
18"	30.0	40.0	46.0	100.0	18.0	—	—	20.4	3.8
20"	34.0	43.0	52.0	110.0	20.0	—	—	24.0	4.1

LENGTH IN FEET OF STRAIGHT PIPE GIVING EQUIVALENT RESISTANCE TO FLOW

NOTE: 1. FOR 135° BEND, USE 50% OF EQUIVALENT LENGTH FOR 90° BEND.
2. L1 IS THE AGGREGATE OF EQUIVALENT LENGTHS FOR ALL PIPELINE FITTINGS AND VALVES IN A GIVEN PIPELINE

TECH-TAYLOR VALVE IS A BALL TYPE CHANGEDOVER DEVICE USED ONLY ON THE DELIVERY SIDE OF THE PUMP

Figure 7-3 Equivalent Lengths of Pipe Fittings and Valves

GROUPS 1 TO 5 IN TABLE SHOW THE APPROXIMATE PROPORTIONS OF VELOCITY HEAD, $H_V = \frac{V^2}{2g}$, WHICH APPLY TO CERTAIN CONDITIONS. V IS USED TO INDICATE THE UP STREAM VELOCITY AND V_1 THE DOWN STREAM VELOCITY.

GROUP	ITEM	HEAD LOSS (ft.)
1.	Loss of head at inlet H_i From pump hopper to pump or from storage tank to pump (a) Flush Connections. (b) Projecting connection and dredge suction pipes. (c) Rounded Connection.	$0.5 \frac{V_1^2}{2g}$ $1.0 \frac{V_1^2}{2g}$ $0.05 \frac{V_1^2}{2g}$
2.	Loss of head due to conical enlargement from pump discharge flange to discharge pipeline	$K_e \frac{(V - V_1)^2}{2g}$
	included angle θ	6° 1.15
	factor K_e	65° 0.14
		* SEE CAMERON PAGE 3-110
3.	Loss of head due to sudden contraction: K_c is a factor depending on ratio $\frac{d_1}{d_2}$ where d_1 is the large diameter and d_2 the small diameter as illustrated below.	$K_c \frac{V_1^2}{2g}$
	Ratio $\frac{d_1}{d_2}$	1.2 1.4 1.6 1.8 2.0 2.5 3.0 4.0 5.0
	Factor K_c	0.08 0.17 0.26 0.34 0.37 0.41 0.43 0.45 0.46
4.	Loss of head due to sudden enlargement:	$\frac{(V - V_1)^2}{2g}$
5.	Loss of head due to conical contraction: e.g. Jet Nozzles	$K_g \frac{(V - V_1)^2}{2g}$

* FOR CONICAL ENLARGEMENTS, MAXIMUM HEAD LOSS OCCURS WHEN INCLUDED ANGLE IS 65°, WHEN $K_e = 1.15$, MINIMUM HEAD LOSS OCCURS WHEN INCLUDED ANGLE IS 6°, WHEN $K_e = 0.14$.

Figure 7-4 Head Losses at Inlet, Contraction and Enlargement

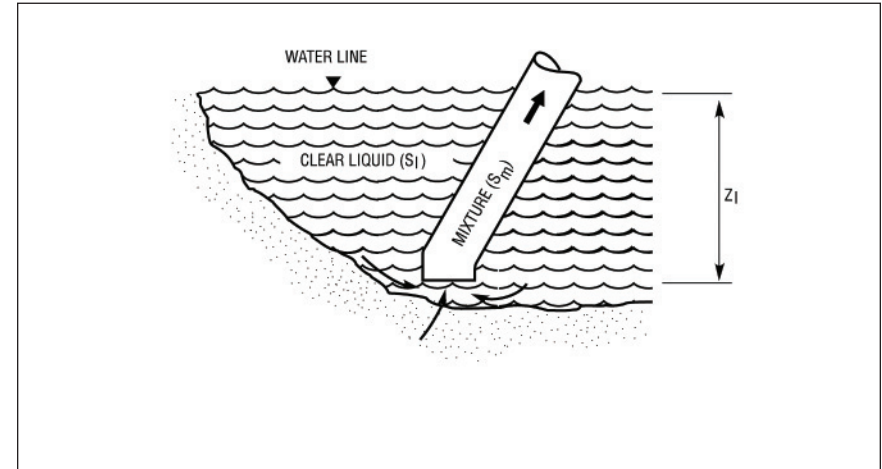

Figure 7-5 Differential Column Head Loss

Section 8 - Velocity

Limiting Settling Velocity

Slurries containing essentially fine particles (predominantly less than 50 microns (0.05mm)) are generally considered non-settling (homogeneous) and can normally be assessed without consideration for settling. In high concentrations however, these slurries often exhibit non-Newtonian flow properties (or rheology) and require special consideration in determining suitable pump and system parameters. Further information can be obtained by contacting your nearest Warman office.

Slurries containing particles predominantly greater than 50 microns are generally considered settling (heterogeneous), which is the case in the majority of slurry pumping applications.

Slurries containing solid particles essentially coarser than 50 microns are transported in suspension by a liquid in a pipe, providing the average velocity, V is no less than the limiting settling velocity V_L . At any velocity below V_L , solids are deposited in the pipeline. This results in increased pipeline friction head loss, with reducing flow rate and may lead to a blockage of the pipeline.

Determination of Limiting Settling Velocity

In order to determine V_L accurately, it is necessary to conduct tests with the slurry on a pipeline test rig. As a practical alternative, where this is not possible, the V_L may be established by a skilled specialist or estimated by one of the following methods, each based on Durand's formula:

Durand's Formula $V_L = F_L \sqrt{2gD (S - S_f) / S_1}$

Where the parameter F_L is dependent upon particle sizing and solids concentration.

Durand's formula was derived initially from tests carried out on slurries of closely-graded particle sizing, (see Figure 8-1).

A closely-graded particle sizing, (for the purposes in this Handbook), is regarded as one where the ratio of particle sizes, expressed as testing screen apertures, does not exceed approximately 2:1, for at least 90% by weight of the total solids in the sample. Subsequent tests indicate that values of F_L , (from Figure 8-1), provide conservative (high) values for V_L in respect of:

- Slurries of more widely-graded particle sizing, and/or
- Slurries with a sizing containing significant proportions of particles finer than 100 μm .

It is important that values of F_L (and V_L) are not excessively conservative (high). Excessively conservative estimates of F_L (and V_L) will result in the high pipeline velocities, high power consumption and high rates of wear on pipes and pumps.

Method (A): ESTIMATING F_L : CLOSELY-GRADED PARTICLE SIZING:

Given values for d_{50} and C_v ; values of F_L are obtained from Figure 8-1.

Method (B): ESTIMATING F_L : WIDELY-GRADED PARTICLE SIZING:

Widely-graded sizing are more commonly encountered in slurry pumping operations.

Figure 8-2 represents the results of field tests on slurries of widely-graded sizing. The particle sizing is simply expressed by the d_{50} term.

The resultant values of F_L (and consequently, V_L) are significantly below those which would be yielded from Figure 8-1.

Effect of Pipe Diameter on Limiting Velocity

As shown in Durand's equation, the limiting velocity generally increases with the square root of the pipe diameter for any given concentration and particle size.

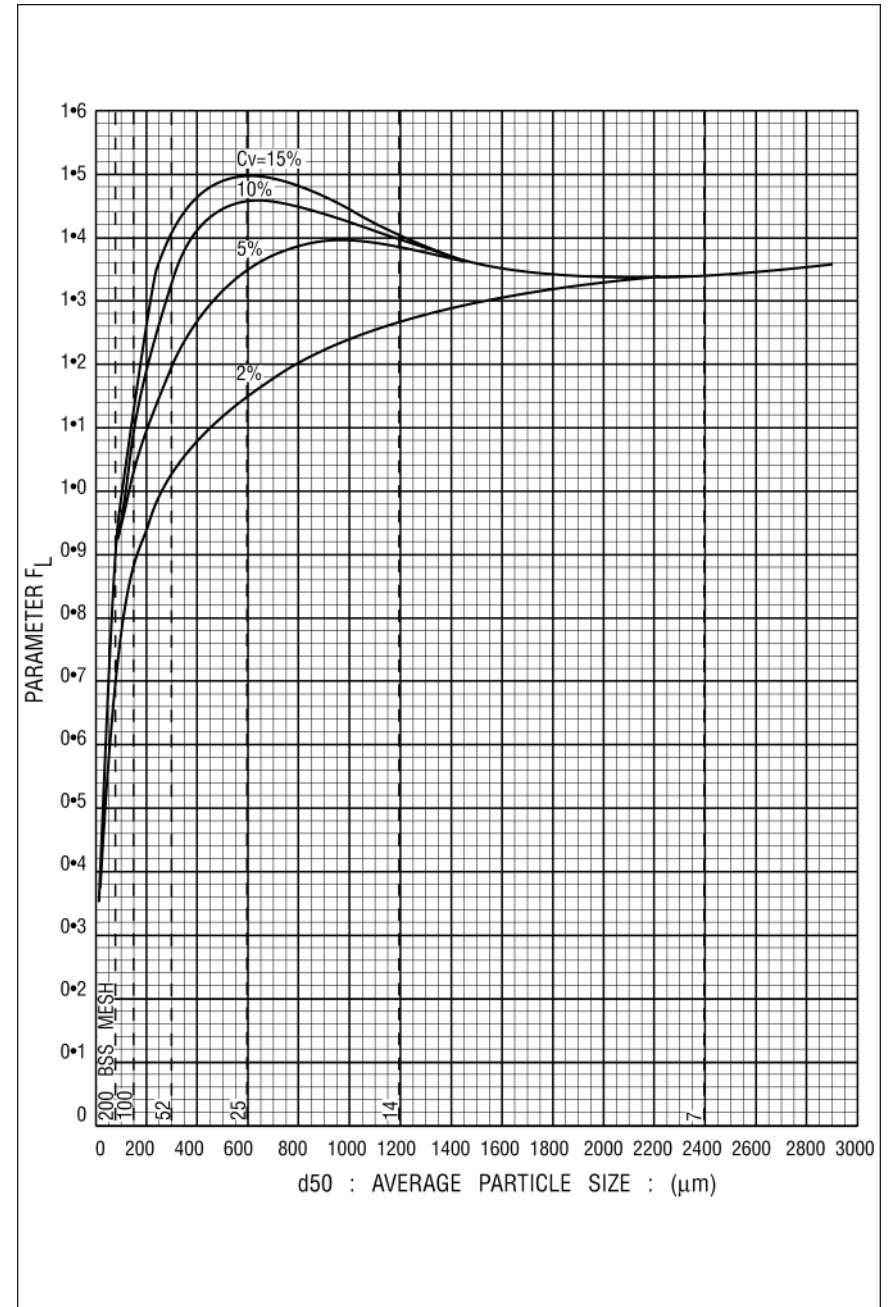

Figure 8-1 Durand's Limiting Settling Velocity Parameter
(For Particles of Closely Graded Sizing)

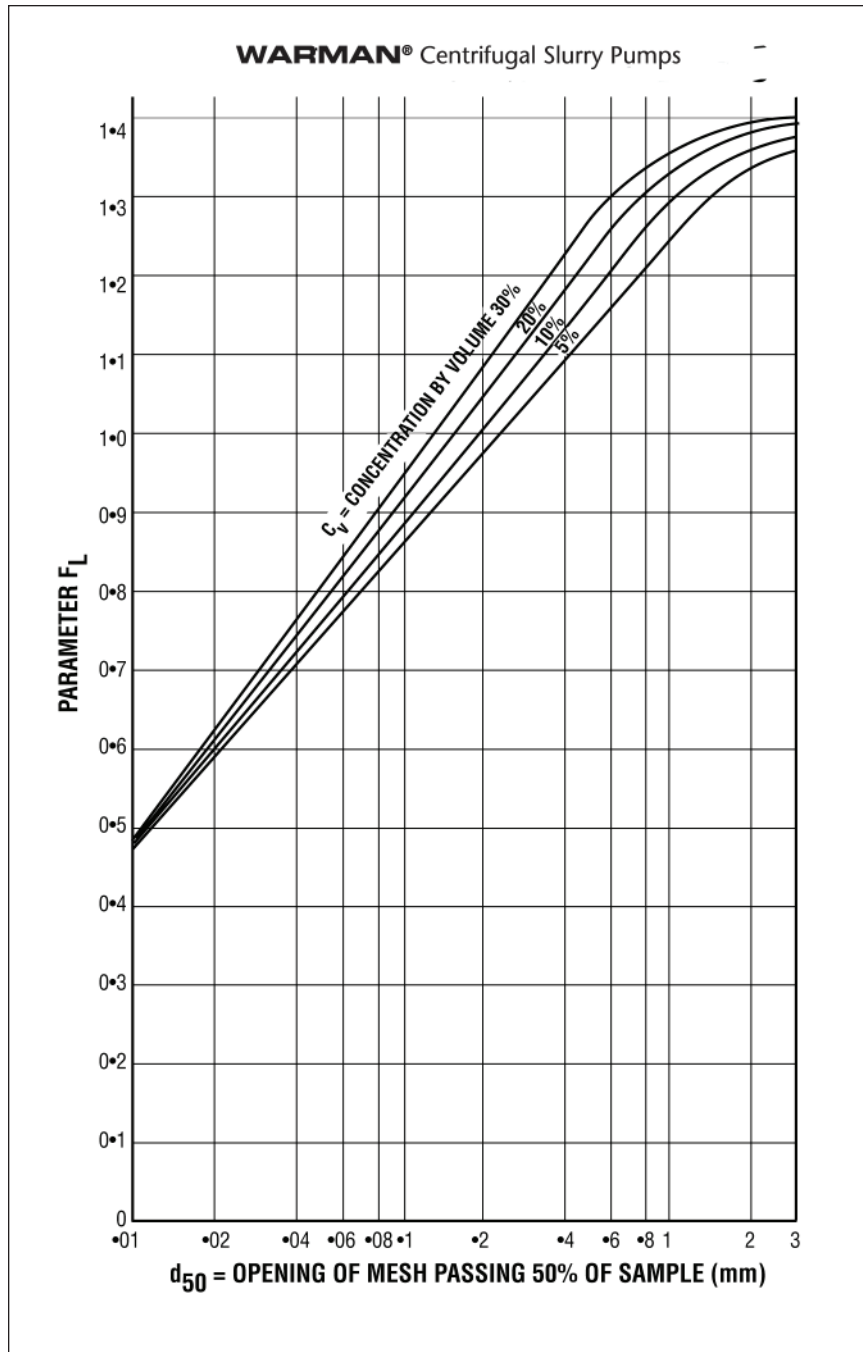

Figure 8-2 Modified Durand's Limiting Settling Velocity Parameter
(For Particles of Widely Graded Sizing)

Section 9 - Net Positive Suction Head

General Notes

One factor limiting the suction performance of a centrifugal pump is the Net Positive Suction Head required at the pump intake to avoid cavitation.

NPSH Required (NPSHr)

The NPSH required by a centrifugal pump, at any given point on the Head/Quantity (H/Q) curve, is the minimum net amount of energy, (expressed in feet of head of the actual mixture being pumped above absolute zero pressure), that the fluid must have at the entrance to the impeller to avoid cavitation.

During cavitation, vapor bubbles form at points where the net positive head falls below the vapor pressure of the liquid. The subsequent collapse of these bubbles, as they flow with the liquid into a zone of higher head, may cause severe erosion of the impeller.

The lowest head in a centrifugal pump occurs behind the leading edge of the vanes in the "eye" of the impeller.

Formation of vapor pockets at these points has the following effects on the pump performance:

- The head developed decreases.
- The efficiency drops.
- Rumbling or crackling noises and vibration are produced, sometimes resulting in mechanical failures.
- The impeller can be subjected to excessive erosion.

Cavitation is a term which is often wrongly applied to conditions of malfunction of a pump, for example, when air is induced into the pump through leaking pipework or when air is induced at the intake to the pump.

Classical references to cavitation in water pumps indicate that, with a given suction system, the pump performance follows the normal H/Q curve from shut-off head to where cavitation commences at a certain flow rate. Beyond this flow rate, the H/Q curve (for that suction system) falls off sharply and drops almost vertically to complete failure of pump performance.

Tests show that this is not the case with slurry pumps, as the H/Q curve does not fall sharply after commencement of cavitation, but falls away gradually from the cavitation-free curve. This is probably due to the use of wide impellers. Vapor bubbles do not form across the whole width of the impeller and the flow is only

partly restricted. Total performance failure does not occur as sharply as it does with narrower water pump impellers.

The Net Positive Head (NPH) at a point in a pipeline is the absolute pressure head at that point, plus the velocity head, less the vapor pressure.

Thus, if a pressure head gauge reading is obtained at a point in a pipeline, the NPH at that point is equal to the gauge head reading, plus atmospheric pressure head, minus the liquid vapor pressure head, plus the velocity head. Gauge readings above atmospheric are taken as positive and below atmospheric as negative.

The NPH at the suction inlet of a pump is called the NPSH and the minimum NPSH required to avoid cavitation is usually shown on pump performance curves as "NPSH required". (NPSH_r)

NPSH Available (NPSH_a)

For a particular pump installation, the NPSH available must be determined from the system conditions and liquid characteristics.

The NPSH available (NPSH_a) must exceed the NPSH required by the pump at the duty point, to prevent cavitation from occurring.

Formula for NPSH_a

Formulas for calculating NPSH_a are shown in Figure 9-1a, b, c and d. All formulas refer to solids free, Newtonian liquids.

The diagrams are schematic only. They are used to clarify symbols and do not necessarily represent the best installation practice.

NOTES:

1. Use equation (1) to calculate NPSH_a from pump tests.
2. Use equation (2) to predict NPSH_a from the installation drawings and design data.
3. Express all the heads as liquid columns of density corresponding to the pumping temperature.
4. Correct the barometric pressure (H_{atm}) for altitude, (Figure 9-2)
5. Typical vapor pressures for water are given in Figure 9-3.

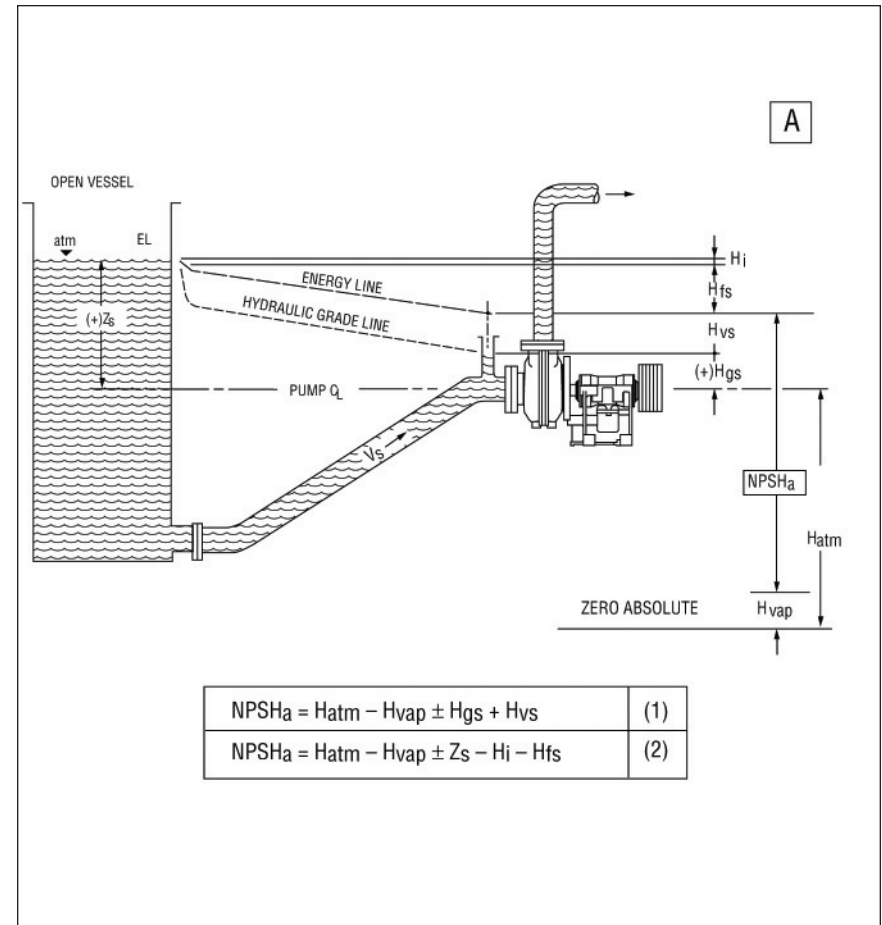

Figure 9-1A NPSH_a for Positive Suction Conditions

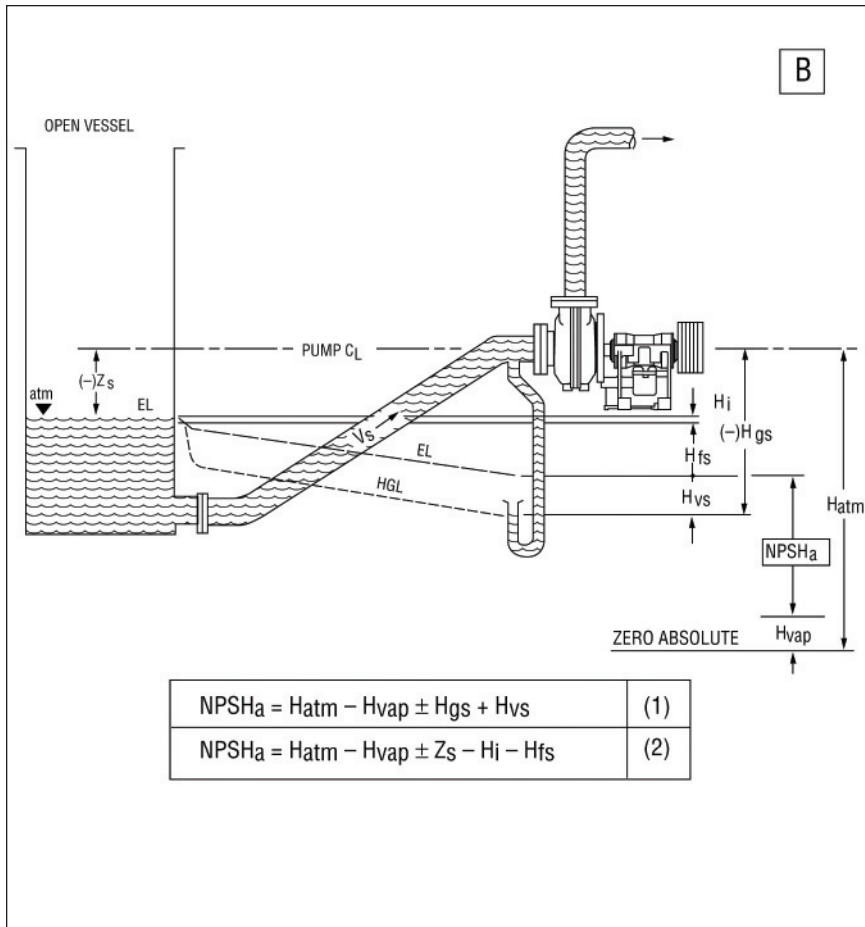

Figure 9-1B $NPSH_a$ for Negative Suction Conditions

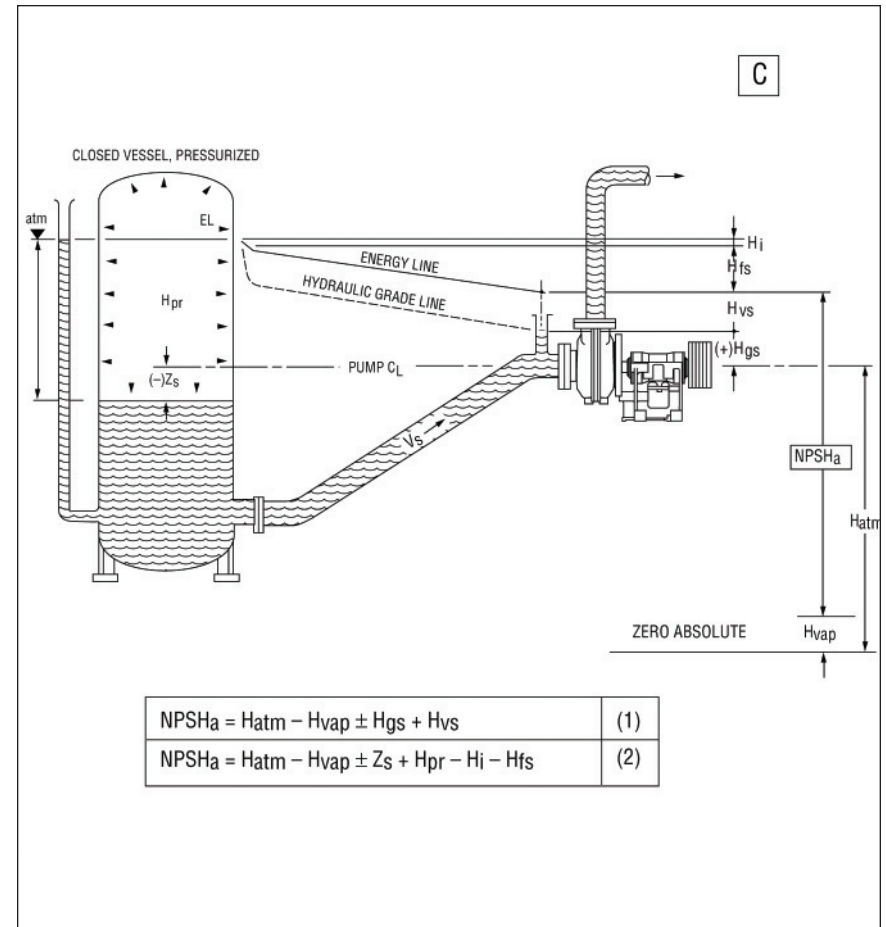

Figure 9-1C $NPSH_a$ Pumping from a Closed Pressurized Vessel

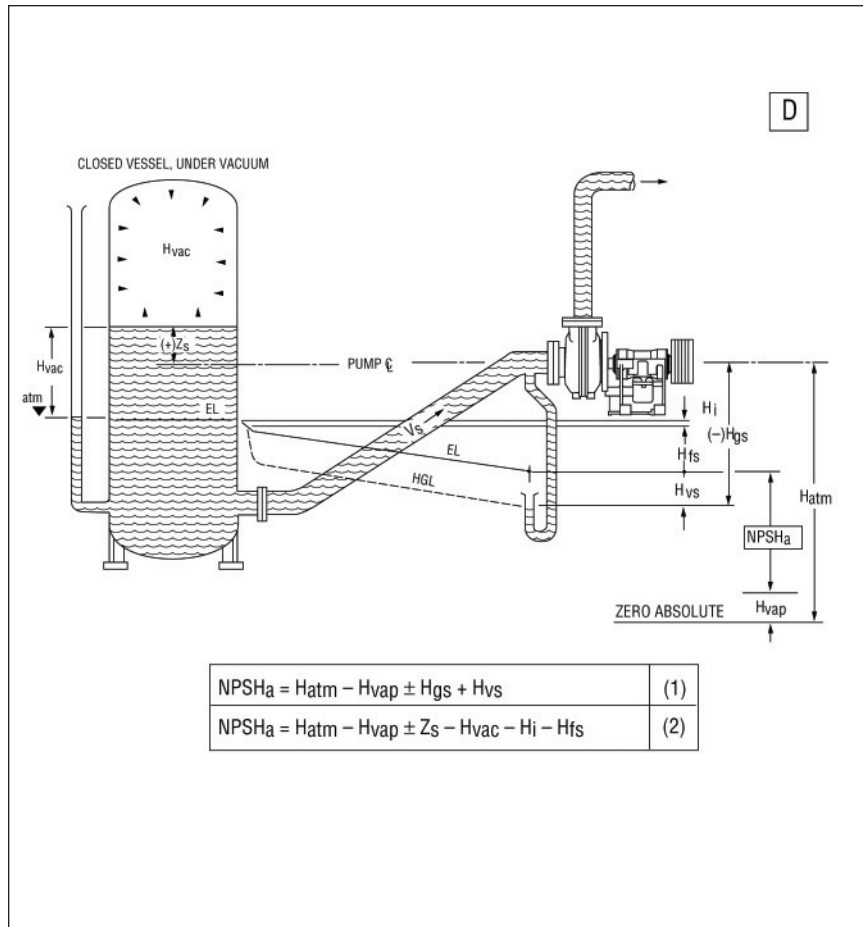

Figure 9-1D $NPSH_a$ Pumping from a Closed Vessel Under Vacuum

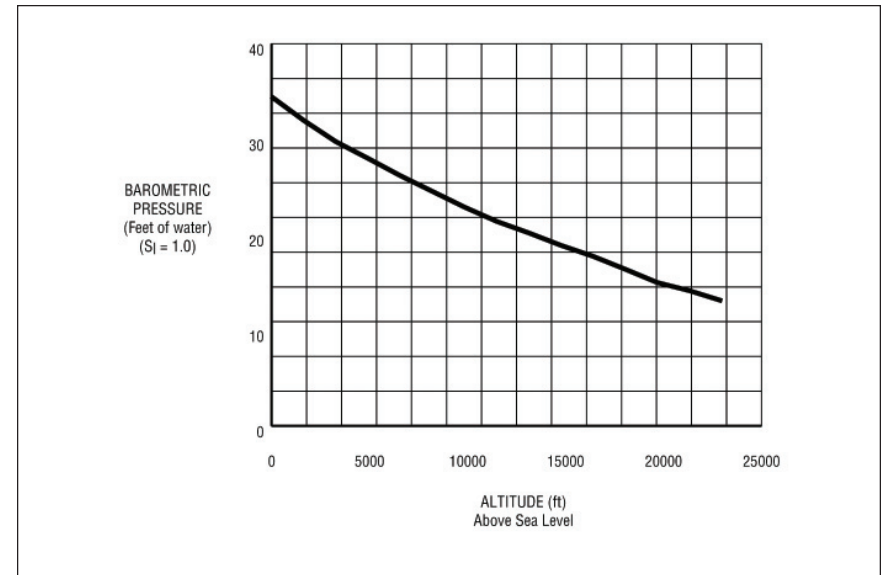

Figure 9-2 Approximate Barometric Pressures

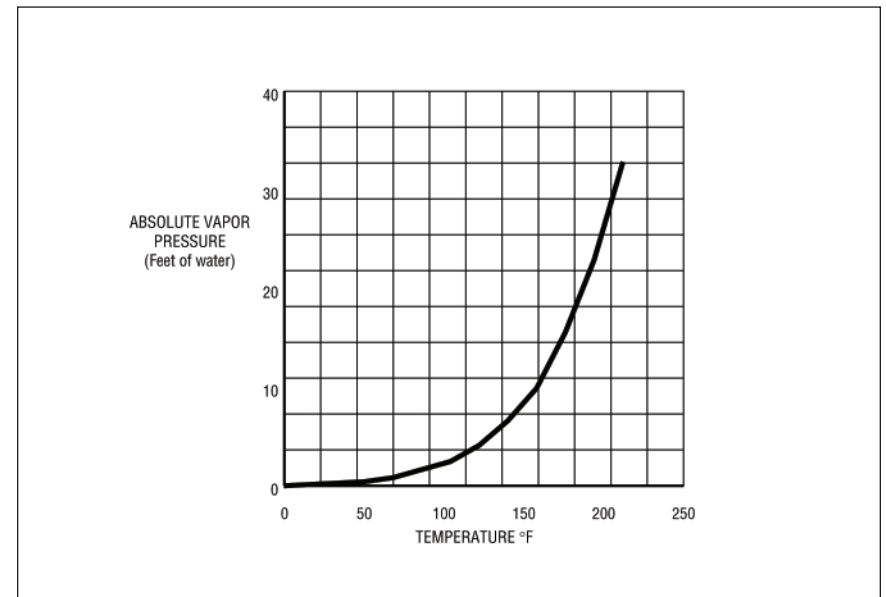

Figure 9-3 Absolute Vapor Pressure of Pure Water

Section 10 - Series Pumping

Introduction

Many pumping duties require slurries to be transported over long distances and/or against very high static discharge heads, for example, against total heads well in excess of heads which can be developed by a single centrifugal slurry pump.

Typical examples include many requirements for the pumping of concentrates, tailings, power station ash and underground fill. The high flow rates required are commonly beyond the capacities of available positive displacement pumps (PDPs). In addition, the overall % efficiency, that is,

$$\frac{\text{(Hydraulic (useful) power imparted to slurry)}}{\text{(Total Electrical power input to motors)}} \times 100\%,$$

of large centrifugal slurry pump installations competes with PDPs, essentially due to:

1. The high efficiency of large centrifugal slurry pumps
2. The higher efficiencies of the lower-ratio drives between electric motors and the centrifugal pumps. These pump applications which require a high Total Head can be handled by series pumping, either as:
 - multi-stage pump units, or
 - separate pumps spaced at intervals along the pipeline route.

Single Pump

Figure 10-1 represents a single centrifugal pump operating at duty point "A", and at pump speed, n_1 . For the required flow rate Q_1 , the pump can develop a head H_1 at an efficiency, em_1 , and at a power consumed of P_1 . That is, the Duty Point "A" is Q_1/H_1 .

NOTE: The hydraulic grade line (H.G.L.) indicates the actual static head available at any point along the length of the pipeline.

Two-Stage Pump Unit

Figure 10-3 represents two identical pumps, arranged in series so that the entire flow discharged from the 1st stage pump is piped under pressure through a short length of piping, directly to the suction flange of the 2nd stage pump into the discharge pipeline. If both pumps are operated at the same speed, n_1 , and as both are handling the same required flow rate, Q_1 , each will develop the same Head, H_1 , at the same efficiency, em_1 , and consume the same power, P_1 .

The total head developed by the 2-stage pump unit combination = $2 \times H_1$, that is, Duty Point "B" is $Q_1/2H_1$

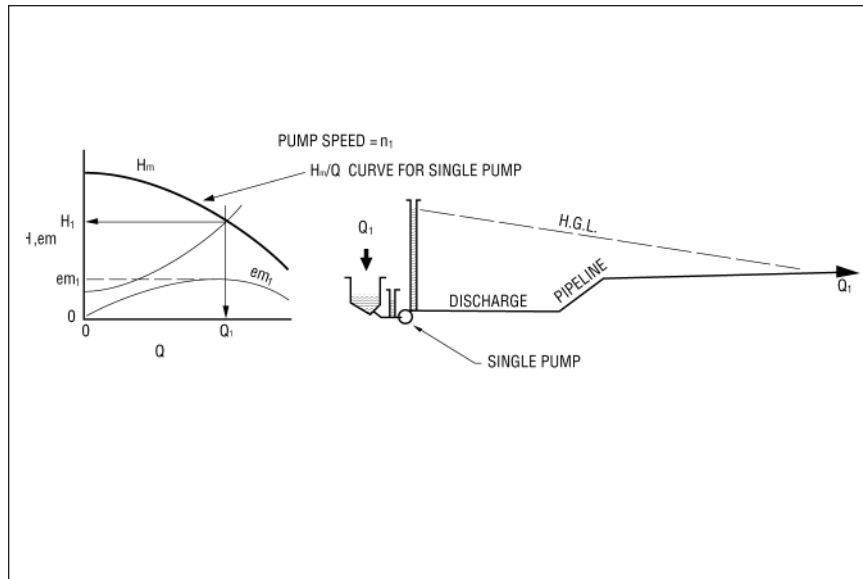

Figure 10-1 Single Pump

Accordingly, both pumps will be operating under the same conditions, except that the Suction Head and the Discharge Head of the 2nd Stage Pump will both be higher by the value of the Discharge Head of the 1st Stage Pump (less small losses in the inter-stage piping).

Four-Stage Pump Unit

Figure 10-4 represents an arrangement similar to Figure 10-3, but extended to represent a 4-stage pump unit where the entire flow passes through all 4 identical pumps prior to entering the discharge pipeline.

If all 4 pumps are identical and are operated at the same speed, n_1 , and as all the pumps are handling the same flow rate, Q_1 , each will develop the same head, H_1 , at the same efficiency, em_1 , and each consume the same power, P_1 .

The total head developed by the 4-stage pump unit combined $H_1 + H_1 + H_1 + H_1 = 4 \times H_1$, that is, Duty Point "C" is $Q_1/4H_1$.

Accordingly, all 4 pumps will be operating under the same conditions except that the Suction Head and the Discharge Head of each successive stage will be progressively higher. Neglecting the small losses in the inter-stage piping and assuming that H_s for the 1st Stage Pump = X (feet) the individual values are found in Table 10-2.

Stage	Suction Head For Stage (ft)	Total Head Developed By Pump (ft)	Power Consumed By Each Pump	Discharge Head for Stage = (ft)
1st Stage	X	H_1	P_1	$X+H_1$
2nd Stage	$X+H_1$	H_1	P_1	$X+2H_1$
3rd Stage	$X+2H_1$	H_1	P_1	$X+3H_1$
4th Stage	$X+3H_1$	H_1	P_1	$X=4H_1$

4-Stage Unit: Total Head Developed = $4H_1$;
Total Power Consumed = $4P_1$

Table 10-2 Calculation of Power and Head for Multi-Stage Sets

If the Total Head Developed by each pump varies from one pump to another, due to different speeds or different effects of wear, the Total Head developed by the Multi-Stage Unit will be the sum of the individual Total Heads Developed by each of the pumps.

Similarly, the Total Power Consumed will be the sum of the individual powers consumed by each of the pumps.

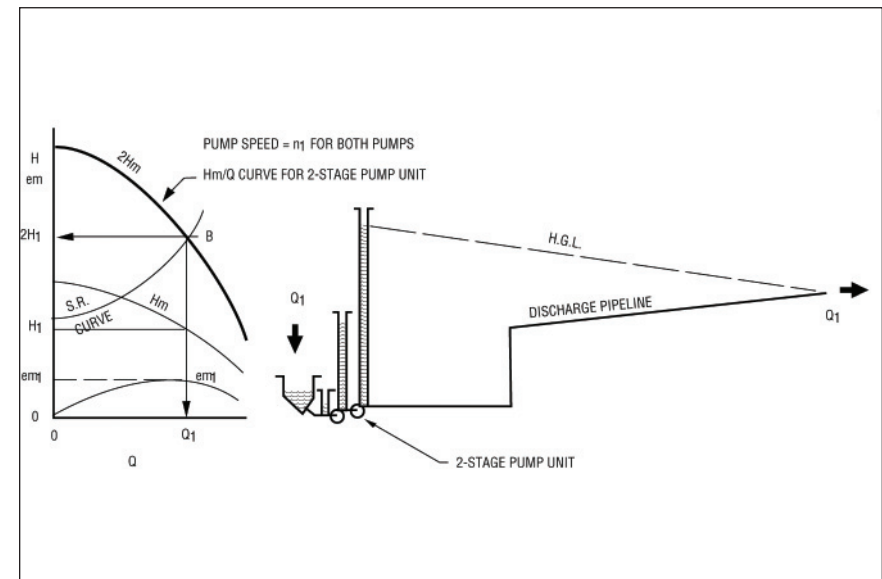

Figure 10-3 Two-Stage Pump Unit

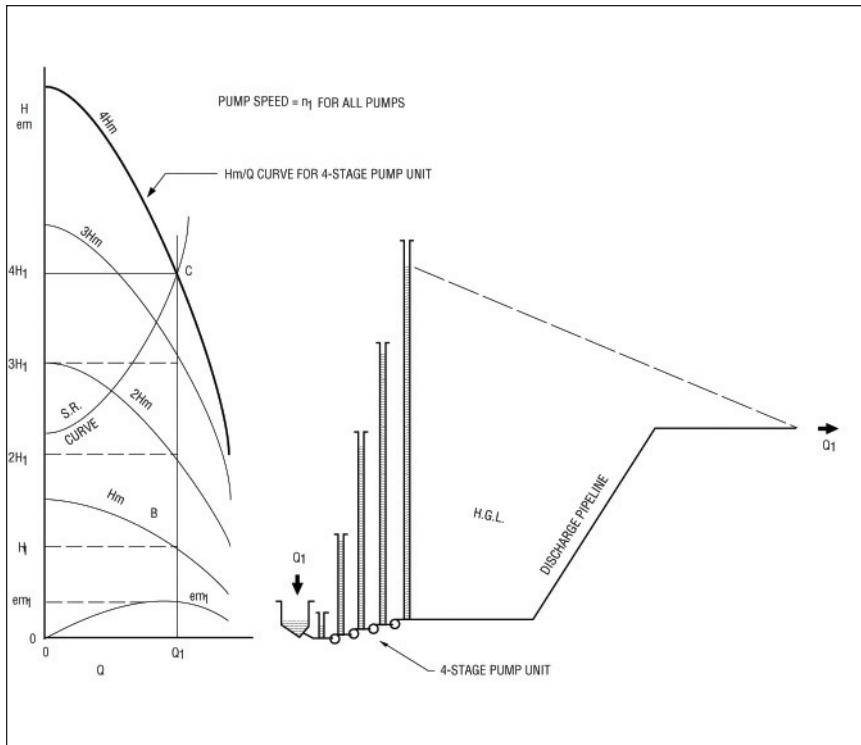

Figure 10-4 Four-Stage Pump Unit

Appendix - Glossary of Terms & Nomenclature

C_g	Concentration of solids in mixture expressed as grams per liter of mixture (g/l)
C_v	Concentration of solids in mixture, by volume (percent)
C_w	Concentration of solids in mixture, by weight (percent)
D	Inside diameter of pipe (ft)
d	Inside diameter of pipe (in)
d_s	Inside diameter of suction pipe (in)
d_d	Inside diameter of discharge pipe (in)
d₅₀	Average particle size of solids in a given dry sample. This size is equal to the screen aperture which would retain exactly 50% by weight of the total sample (mm or μm)
e_m	Efficiency of pump when pumping mixture (percent)
ER	Efficiency Ratio
e_w	Efficiency of pump when pumping water (percent)
f	Darcy Friction Factor (dimensionless)
F_l	Limiting Settling Velocity factor (dimensionless)
g	Gravitational constant (32.2 ft/sec ²)
h	Head symbol utilized for sundry purposes
H	Total dynamic head required by a system: Head of mixture (feet)
H_{atm}	Atmospheric Pressure at Pump Location: Head of mixture (feet)
H_d	Total Discharge Head: Head of mixture (feet)
H_f	Friction Head Loss: Head of mixture (feet)
H_{fd}	Friction Head Loss in Discharge Pipe: Head of mixture (feet)
H_{fs}	Friction Head Loss in Suction Pipe: Head of mixture (feet)
H_{gd}	Discharge Gauge Head (above atmospheric pressure): Head of mixture (feet)
H_{gs}	Suction Gauge Head: Head of mixture (feet)
H_i	Inlet Head Loss: Head of mixture (feet)
H_m	Total Dynamic Head Developed by Pump when Pumping Mixture: Head of mixture (feet)
HR	Head Ratio: H _m /H _w

H_{pf}	Exit Gauge Pressure Head, above atmospheric pressure, at exit from pipeline: Head of mixture (feet)
H_{pr}	Gauge Pressure Head, above atmospheric pressure, of gas or vapor maintained over mixture surface in a closed supply vessel: Head of mixture (feet)
H_s	Total Suction Head: (+ve) or (-ve): Head of mixture (feet)
H_{vac}	Gauge Vacuum Head, below atmospheric pressure, of gas or vapor maintained over mixture surface in a closed supply vessel: Head of mixture (feet)
H_{vap}	Absolute Vapor Pressure head of suspending liquid at pumping temperature: Head of mixture pumped (feet)
H_v	Velocity Head, at any given point of evaluation: Head of mixture (feet)
H_{vd}	Velocity Head, in the pump discharge pipe: Head of mixture (feet)
H_{ve}	Exit Velocity Head Loss, at final discharge from pipeline: Head of mixture (feet)
H_{vs}	Velocity Head, in the pump suction pipe at suction tapping point: Head of mixture (feet)
H_w	Total Dynamic Head, developed by pump when pumping water: Head of water (feet)
L	Total Equivalent Length of Pipe = L _a + L _f (feet)
L_a	Total Actual Length of Pipe (feet)
L_r	Aggregate of Equivalent Lengths for all valves, bends and fittings contributing to Friction Head Loss in Pipeline (feet)
L_s	L for Suction Pipe (feet) (Note: L _s = L _{as} + L _{fs})
L_{as}	L _a for Suction Pipe (feet)
L_{fs}	L _f for Suction Pipe (feet)
L_d	L for Discharge Pipe (feet) (Note: L _d = L _{ad} + L _{fd})
L_{ad}	L _a for Discharge Pipe (feet)
L_{fd}	L _f for Discharge Pipe (feet)
M	Mass flow rate of dry solids (t/h)
n	Pump Rotational Speed (revolutions/minute: r/min or RPM)
NPSH_a	Net Positive Suction Head available at Pump Suction Flange: Head of mixture (feet)
NPSH_r	Net Positive Suction Head required at Pump Suction Flange: Head of mixture (feet)

N_R	Reynolds Number (dimensionless)
P	Power consumed at pump shaft (HP)
Pr	Pressure (psi)
Q	Mixture flow rate (gallons per minute) GPM
S	Specific Gravity of Dry Solids
SG	Specific Gravity
S_l	Specific Gravity of Liquid or Transporting Medium
S_m	Specific Gravity of Mixture
V	Average Velocity of Mixture in a pipe (f/s)
V_d	V in Pump Discharge Pipe (f/s)
V_e	Horizontal exit velocity from the pipe (f/s)
V_L	Limiting Settling Velocity of Mixture (f/s)
V_s	V in Pump Suction Pipe (f/s)
Z	Net Static Head
Z_c	Differential Column Head: Head of mixture (ft)
Z_d	Static Discharge Head
Z_l	Vertical height of suction pipe conveying slurry and surrounded by a liquid of Specific Gravity lower than that of the mixture pumped (ft)
Z_s	Static Suction Head: Vertical height from mixture supply surface level to pump center-line (ft)
Z_{sm}	Effective Positive Static Suction Head above (+ve) pump center-line: Head of mixture (ft)