

<b>Electrical Characteristics</b>										
Frequency	Hz	50				60				
Voltage (series star)	V	380	400	415	440	415	440	460	480	
Rated power class H	kVA	40	40	40	32	47	48	48	48	
	kW	32	32	32	25,6	37,6	38,4	38,4	38,4	
Rated power class F	kVA	37	37	37	30	45	46	46	46	
	kW	29,6	29,6	29,6	24	36	36,8	36,8	36,8	
Regulation with SR7/2		±1,5 % with any power factor and speed variations between -5% +30%								
Insulation class		H								
Execution		Brushless								
Stator winding		12 ends								
Rotor		with damping cage								
Efficiencies class H	4/4	%	88,5	88,6	88,3	88,1	89,1	89,6	89,8	90
(see graph. for details)	3/4	%	88,8	89,1	89	88,7	89,9	90,2	90,4	90,6
	2/4	%	87,2	87,3	87,3	87,3	88,7	88,8	88,9	89
	1/4	%	84,9	85	84,8	84,3	87	87	87	87
Reactances (f. l.cl. F)	Xd	%	210,5	190	176,5	125,6	248,9	226,1	206,9	190
	Xd'	%	15,84	14,3	13,28	9,45	18,73	17,02	15,57	14,3
	Xd''	%	11,08	10	9,29	6,61	13,10	11,90	10,89	10
	Xq	%	108,6	98	91,0	64,8	128,4	116,6	106,7	98
	Xq'	%	108,6	98	91,0	64,8	128,4	116,6	106,7	98
	Xq''	%	33,9	30,6	28,4	20,2	40,1	36,4	33,3	30,6
	X <sub>2</sub>	%	23,82	21,5	19,97	14,21	28,16	25,59	23,41	21,5
	X <sub>0</sub>	%	2,99	2,7	2,51	1,79	3,54	3,21	2,94	2,7
Short Circuit Ratio	Kcc		0,70	0,80	0,90	1,30	0,40	0,60	0,70	0,80
Time Constants	Td'	sec.	0,061							
	Td''	sec.	0,015							
	Tdo'	sec.	1,32							
	Tα	sec.	0,031							
Short Circuit Current Capacity		%	>300				>350			
Excitation at no load	Amp.		0,6	0,7	1	1,3	0,3	0,4	0,5	0,6
Excitation at full load	Amp.		2,1	2,2	2,4	2,8	2	1,9	2	2,1
Overload (long-term)		%	1 hour in a 6 hours period 110% rated load							
Overload per 20 sec.		%	300							
Stator Winding Resistance (20°C)	Ω		0,078							
Rotor Winding Resistance (20°C)	Ω		2,163							
Exciter Resistance (20 °C)	Ω		Rotor : 0,64				Stator : 10,6			
Heat dissipation at f.l.cl.H	W		4158	4117	4240	3458	4600	4457	4362	4267
Telephone Interference			FHT < 2%				TIF < 45			
Radio interference			EN50081-1, EN50082-1, VDE0875K. For others standards apply to factory							
Waveform Distors.(THD) at f. load	LL/LN %		3,7 / 3,6							
Waveform Distors.(THD) at no load	LL/LN %		3,2 / 3,1							
<b>Mechanical characteristics</b>										
Protection			IP 21 (other protection on request)							
DE bearing			6312-2RS							
NDE bearing			6309-2RS							
Weight of wound stator assembly	kg		62,5							
Weight of wound rotor assembly	kg		43							
Weight of complete generator	kg		214							
Maximun overspeed	rpm		2250							
Unbalanced magnetic pull at f.l.cl.F	kN/mm		4,5							
Cooling air requirement	m <sup>3</sup> /min		11,8				14,5			
Inertia Constant (H)	sec.		0,108				0,13			
Noise level at 1m/7m	dB(A)		75 / 60				79 / 64			

**50 Hz**

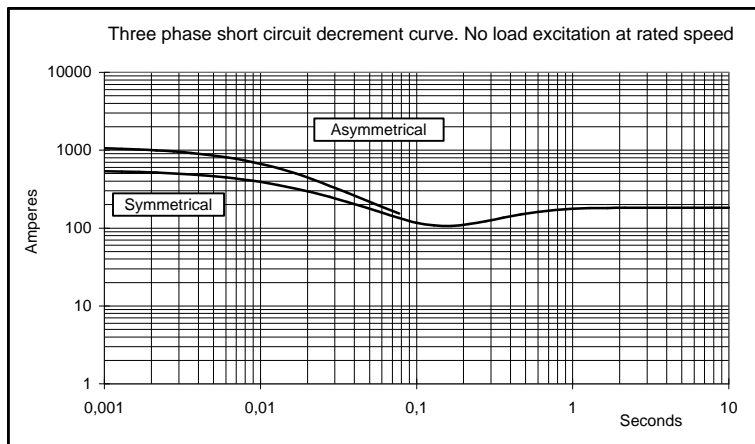

**60 Hz**

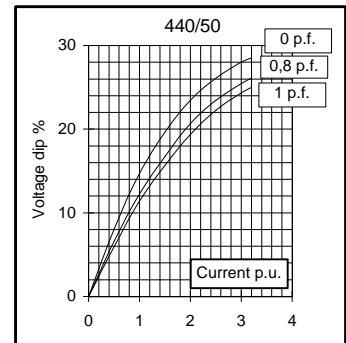
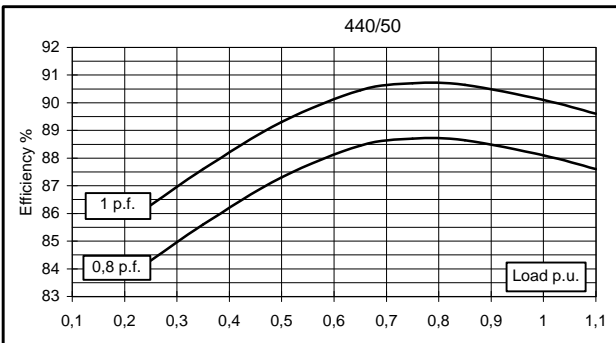
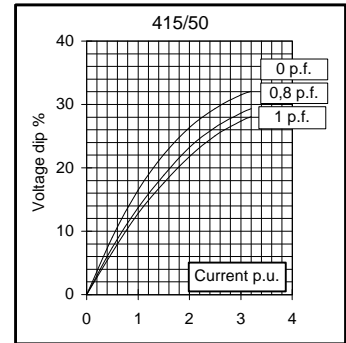
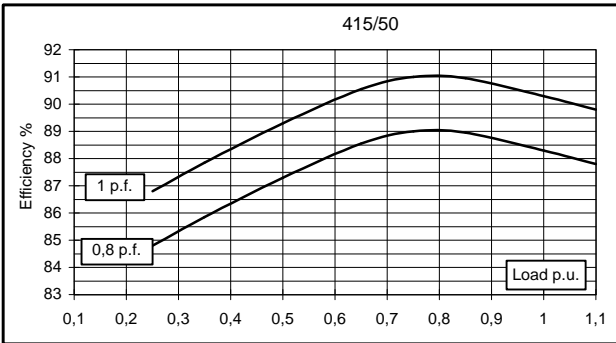
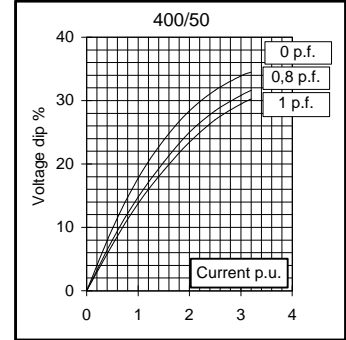
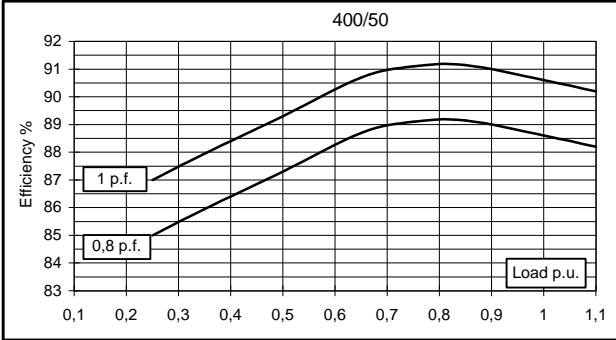
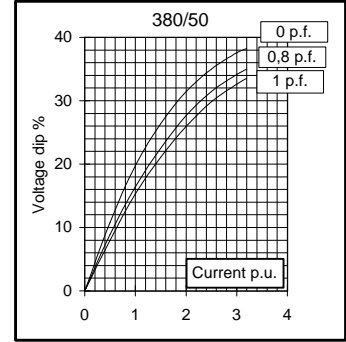
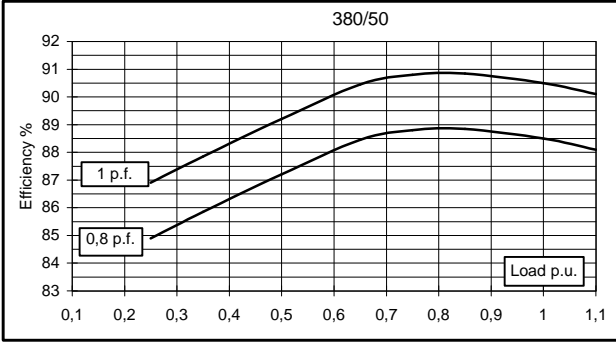
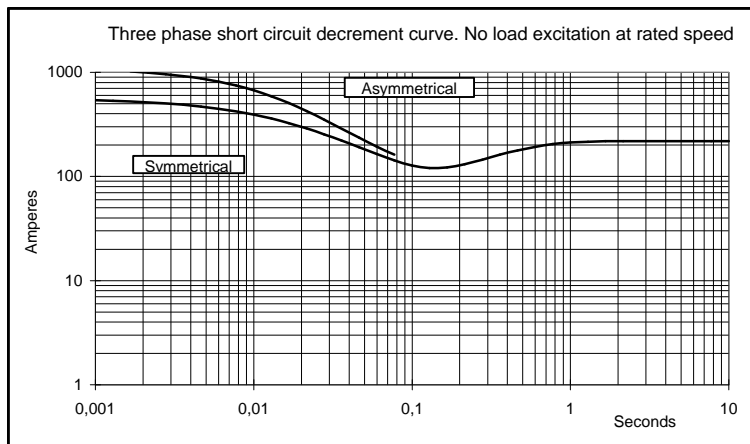
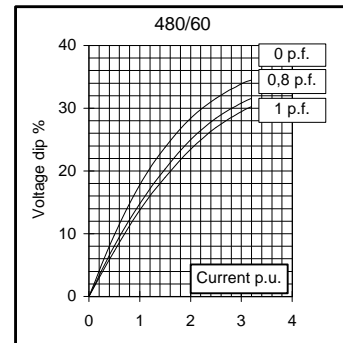
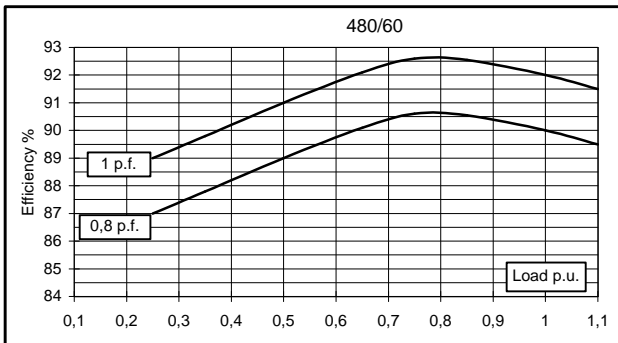
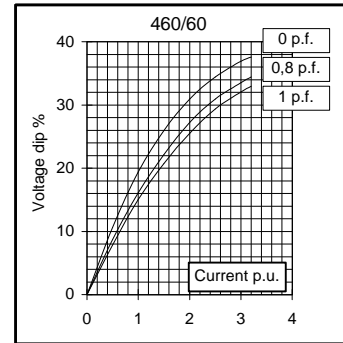
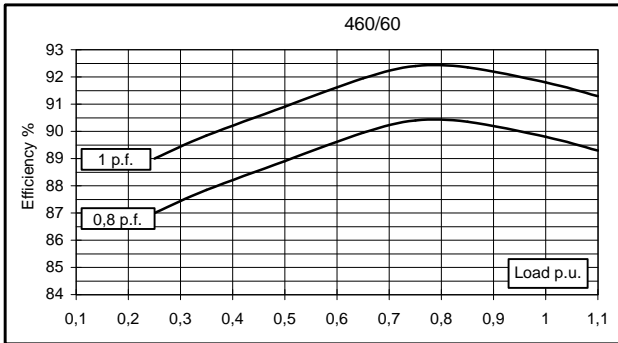
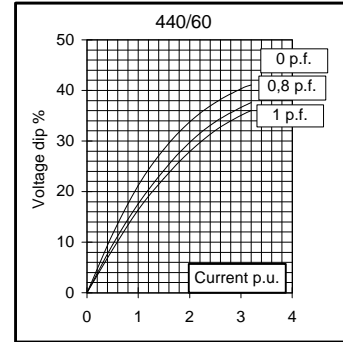
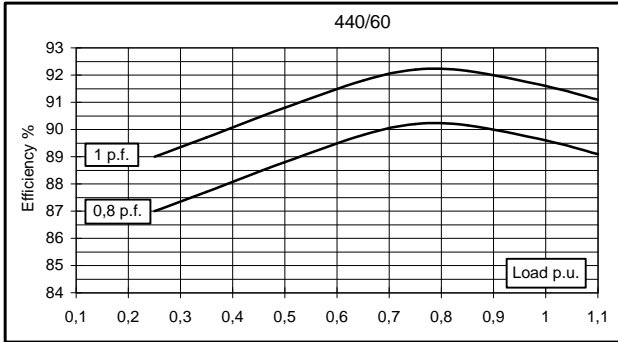
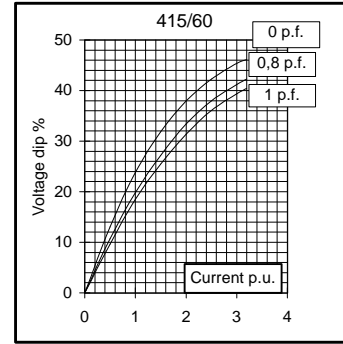
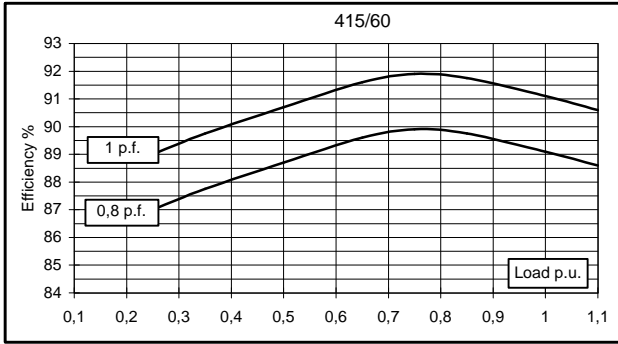

## TWO BEARING MOMENTS OF INERTIA

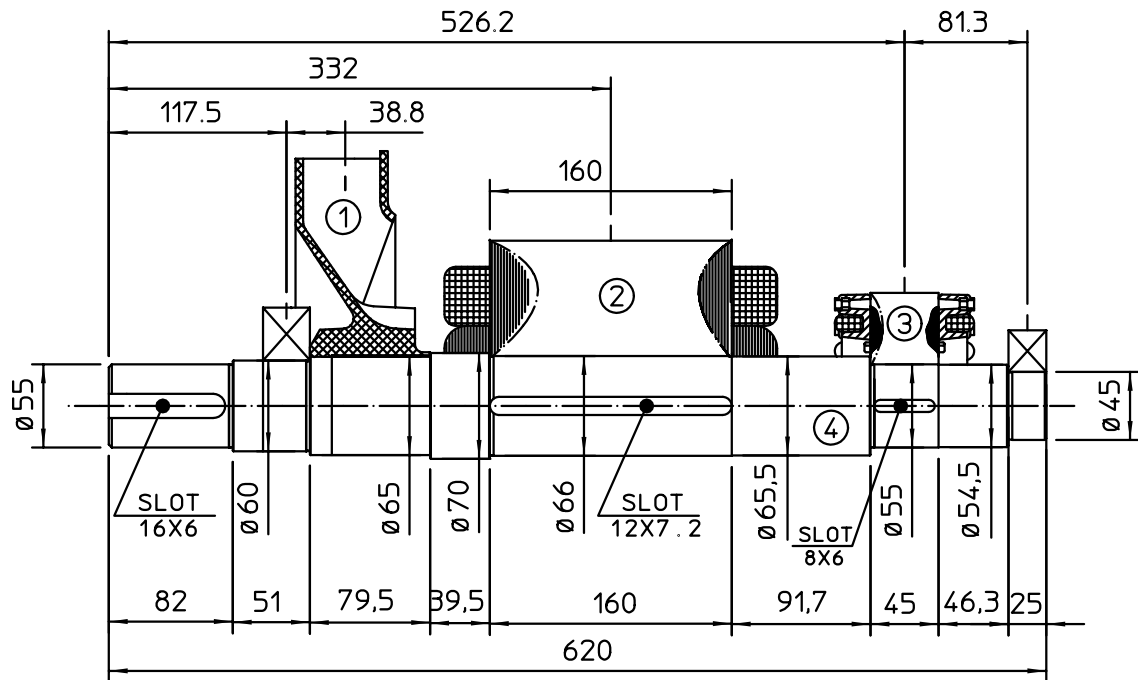

COMPONENT	WEIGHT kg	J kgm <sup>2</sup>
1 FAN	2.3	0.0224
2 MAIN ROTOR	43.5	0.3088
3 EX. ROTOR	5.4	0.012
4 SHAFT	14.6	0.0062
TOTAL	65.8	0.3494

## TWO BEARING DIMENSIONS

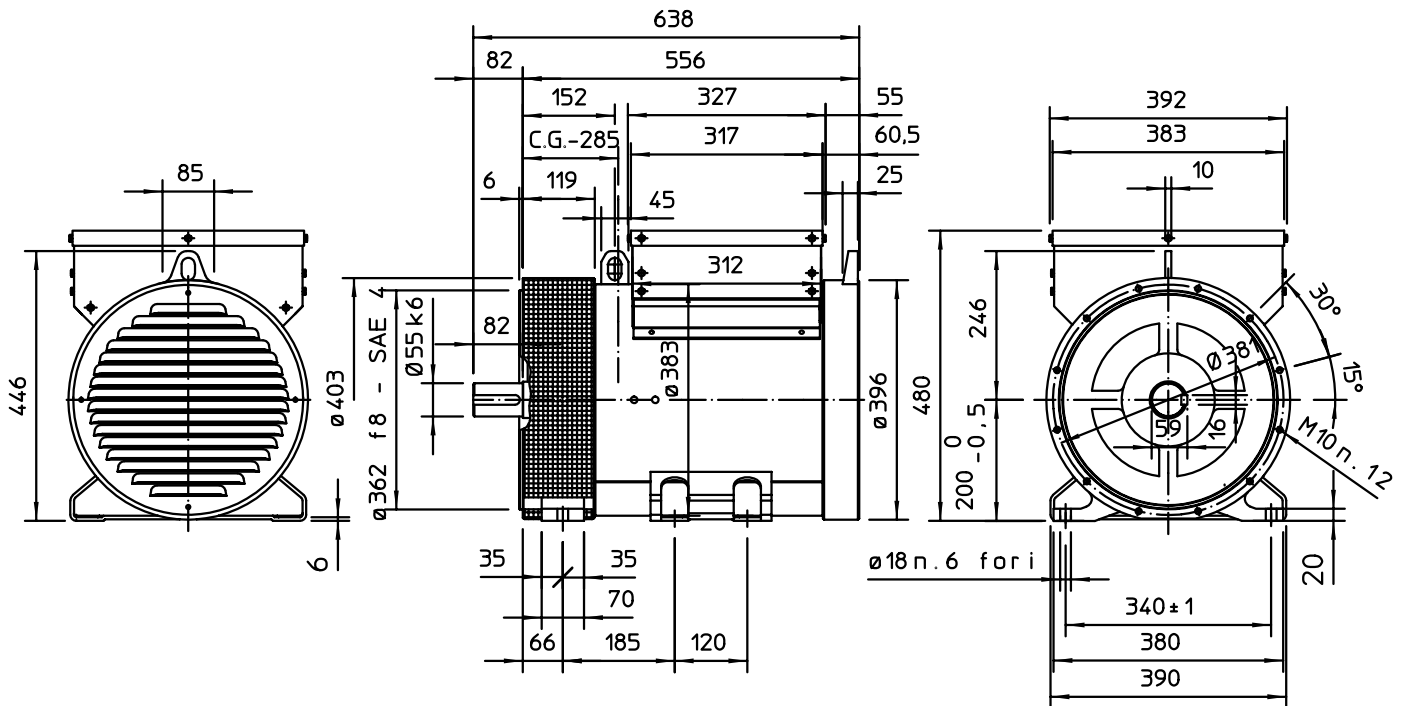

C.G. = GRAVITY CENTER

## SINGLE BEARING MOMENTS OF INERTIA

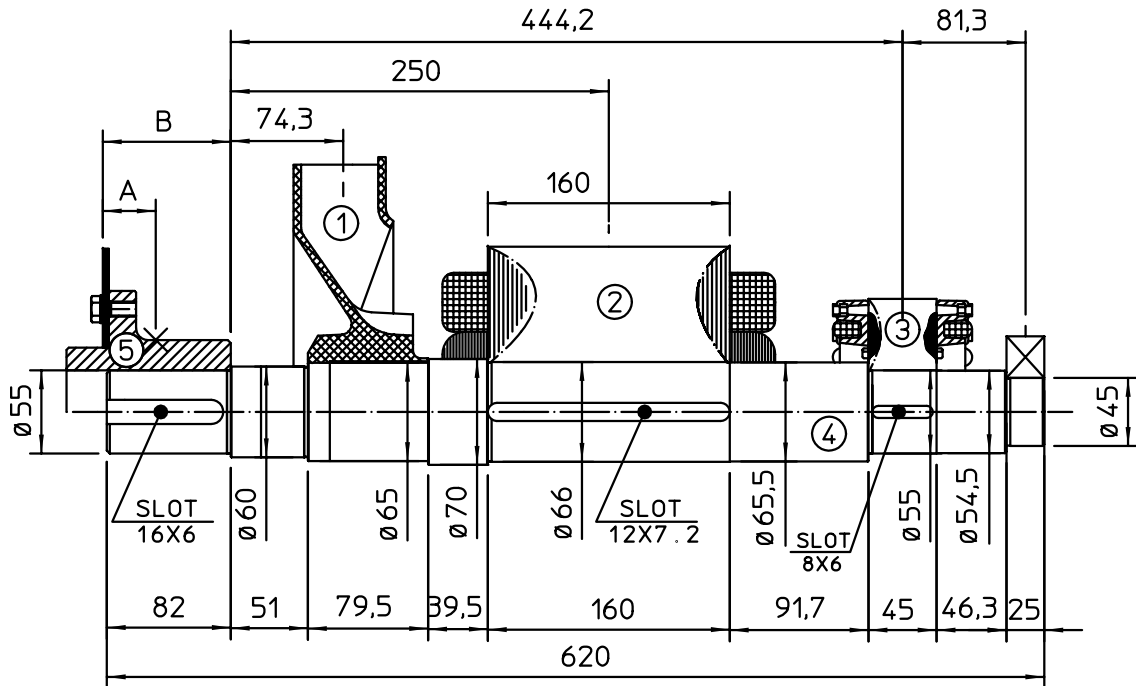

COMPONENT	WEIGHT kg	J kgm <sup>2</sup>
1 FAN	2.3	0.0224
2 MAIN ROTOR	43.5	0.3088
3 EX. ROTOR	5.4	0.012
4 SHAFT	14.6	0.0062
TOTAL	65.8	0.3494

SAE No	SHAFTS COUPLING FLEX PLATE			
	A	B	WEIGHT kg	J kgm <sup>2</sup>
6,5	26,1	75,2	4,2	0,0225
7,5	25,7	75,2	4,4	0,0256
8	38,25	106,9	7,2	0,0314
10	32,7	98,7	8,7	0,0485
11,5	24	84,5	8,3	0,0372

## SINGLE BEARING DIMENSIONS

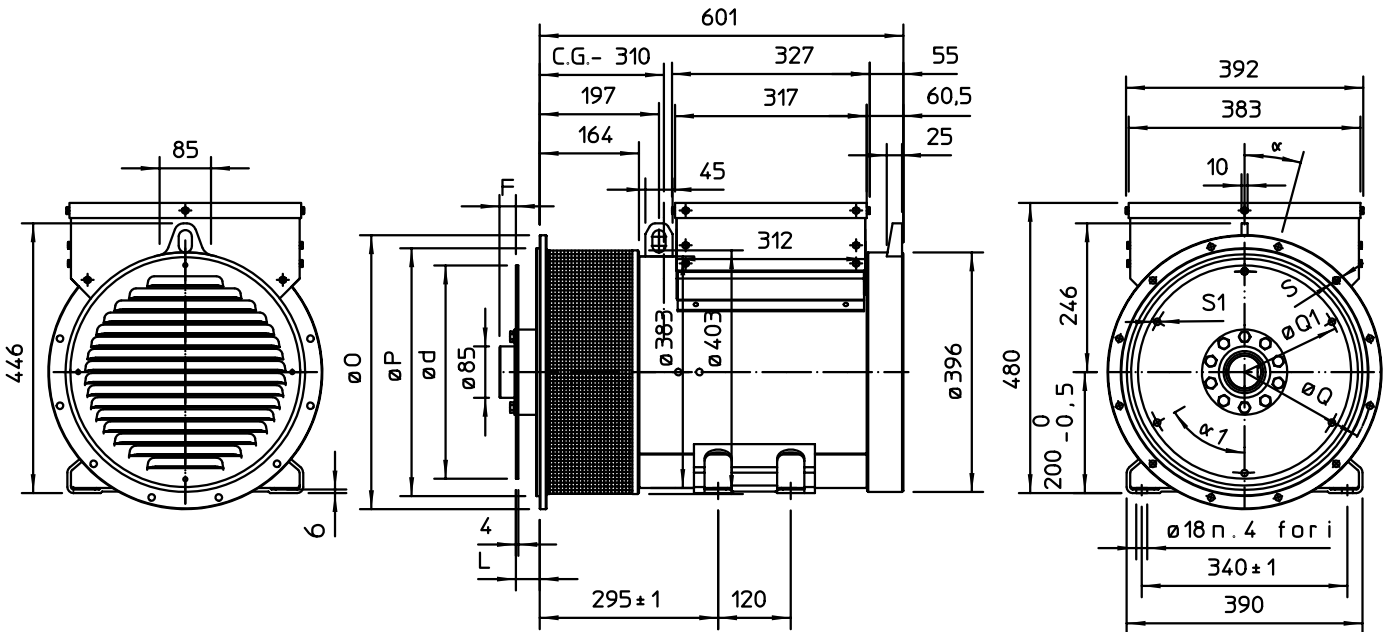

SAE No	DISC COUPLING						
	L	d	Q1	No holes	S1	a1	F
6,5	30,2	215,9	200	6	9	60°	7
7,5	30,2	241,3	222,25	8	9	45°	7
8	62	263,52	244,47	6	11	60°	2
10	53,8	314,32	295,27	8	11	45°	10
11,5	39,6	352,42	333,37	8	11	45°	24

SAE No	FLANGE					
	O	P	Q	No holes	S	a
5	356	314,3	333,4	8	11	22°30'
4	403	362	381	12	11	15°
3	451	409,6	428,6	12	11	15°
2	489	447,7	466,7	12	11	15°
1	552	511,2	530,2	12	11	15°

C.G. = GRAVITY CENTER