

Electrical Characteristics										
Frequency	Hz	50				60				
Voltage (series star)	V	380	400	415	440	415	440	460	480	
Rated power class H	kVA	105	105	105	85	115	126	126	126	
	kW	84	84	84	68	92	101	101	101	
Rated power class F	kVA	95	95	95	77	104	114	114	114	
	kW	76	76	76	61,6	83,2	91,2	91,2	91,2	
Regulation with UVR6		±1% with any power factor and speed variations between -5% +30%								
Insulation class		H								
Execution		Brushless								
Stator winding		12 ends								
Rotor		with damping cage								
Efficiencies class H	4/4	%	92,1	92,2	91,9	91,7	93,1	93,6	93,7	93,8
(see graph. for details)	3/4	%	92,2	92,5	92,4	92,1	93,6	93,8	93,9	94,1
	2/4	%	90,6	90,7	90,7	90,5	92	92,1	92,2	92,3
	1/4	%	87,2	87	86,8	86,8	88,2	88,2	88,2	88
Reactances (f. l.cl. F)	Xd	%	254,8	230	213,7	153,9	280,8	273,7	250,4	230
	Xd'	%	19,5	17,6	16,4	11,8	21,5	20,9	19,2	17,6
	Xd''	%	6,3	5,7	5,3	3,8	7,0	6,8	6,2	5,7
	Xq	%	165,8	149,6	139,0	100,1	182,7	178,0	162,9	149,6
	Xq'	%	165,8	149,6	139,0	100,1	182,7	178,0	162,9	149,6
	Xq''	%	34,6	31,2	29,0	20,9	38,1	37,1	34,0	31,2
	X ₂	%	20,5	18,5	17,2	12,4	22,6	22,0	20,1	18,5
	X ₀	%	3,9	3,5	3,3	2,3	4,3	4,2	3,8	3,5
Short Circuit Ratio	Kcc		0,41	0,47	0,61	0,90	0,32	0,35	0,41	0,47
Time Constants	Td'	sec.	0,0393							
	Td''	sec.	0,0055							
	Tdo'	sec.	1,70							
	Tα	sec.	0,0146							
Short Circuit Current Capacity		%	>300				>350			
Excitation at no load	Amp.		0,5	0,6	0,8	1,1	0,2	0,3	0,4	0,5
Excitation at full load	Amp.		2	2,2	2,3	2,6	1,7	1,9	2	2,2
Overload (long-term)		%	1 hour in a 6 hours period 110% rated load							
Overload per 20 sec.		%	300							
Stator Winding Resistance (20°C)	Ω		0,02							
Rotor Winding Resistance (20°C)	Ω		2,951							
Exciter Resistance (20 °C)	Ω		Rotor : 0,410				Stator : 15,28			
Heat dissipation at f.l.cl.H	W		7205	7106	7404	6155	6818	6892	6777	6663
Telephone Interference			FHT < 2%				TIF < 40			
Radio interference			EN50081-1; EN50082-1; VDE0875K. For others standards apply to factory							
Waveform Distors.(THD) at f. load	LL/LN %		1,8 / 1,9							
Waveform Distors.(THD) at no load	LL/LN %		2,8 / 2,9							
Mechanical characteristics										
Protection			IP 21 (other protection on request)							
DE bearing			6314.2RS							
NDE bearing			6311.2RS							
Weight of wound stator assembly	kg		126							
Weight of wound rotor assembly	kg		81							
Weight of complete generator	kg		393							
Maximun overspeed	rpm		2250							
Unbalanced magnetic pull at f.l.cl.F	kN/mm		5,1							
Cooling air requirement	m ³ /min		19,3				23			
Inertia Constant (H)	sec.		0,111				0,133			
Noise level at 1m/7m	dB(A)		79 / 65				83 / 69			

50 Hz

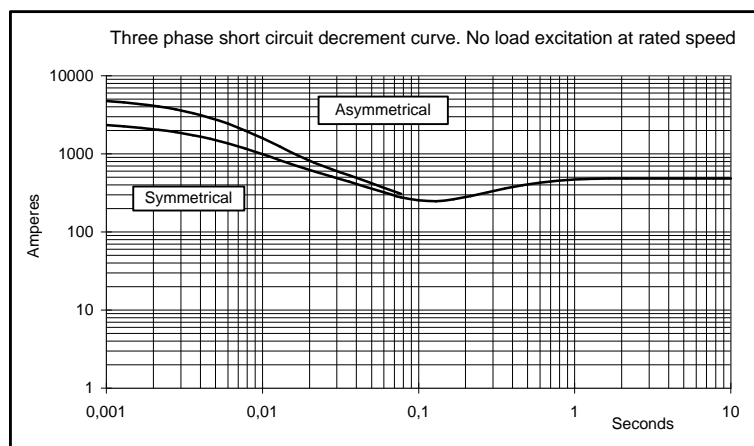

60 Hz

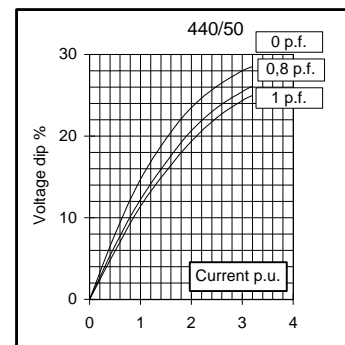
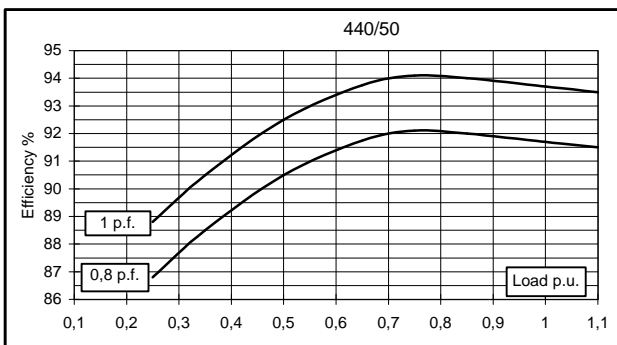
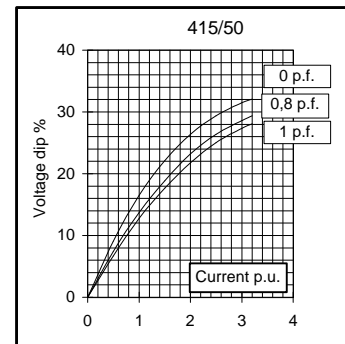
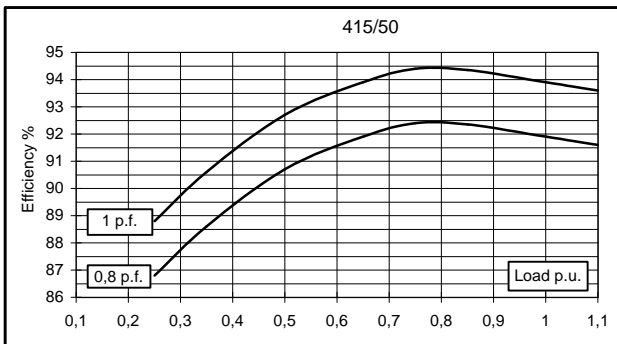
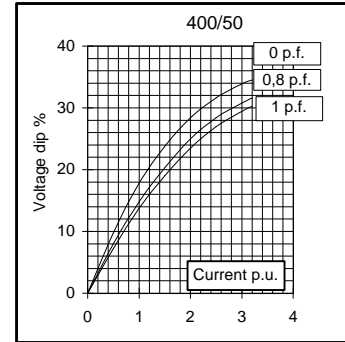
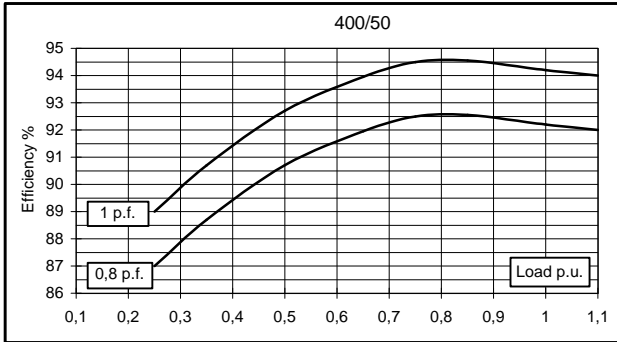
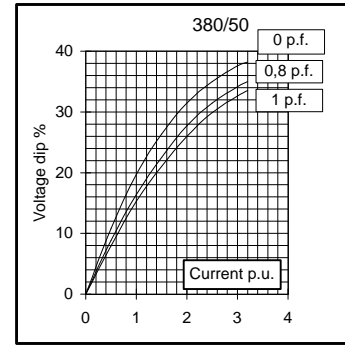
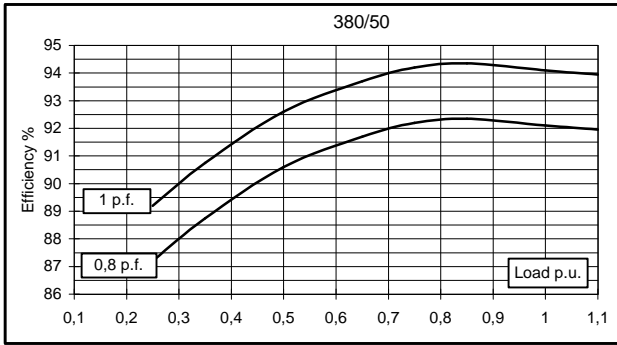
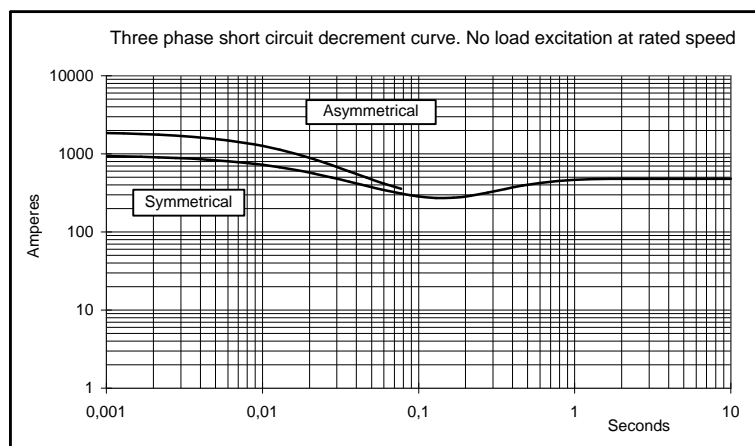
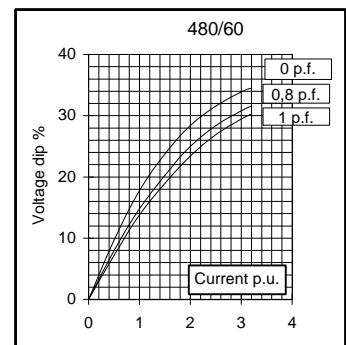
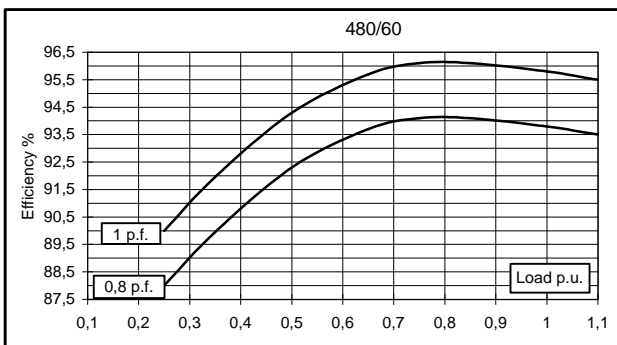
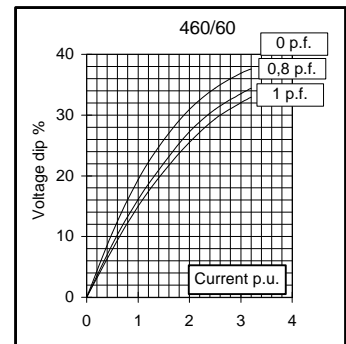
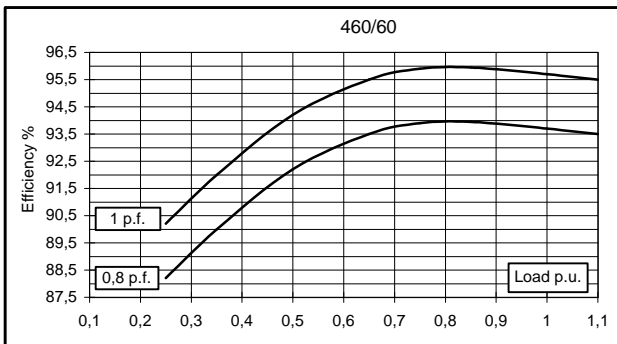
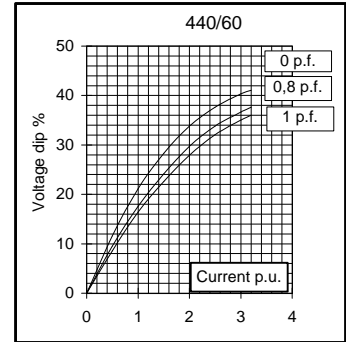
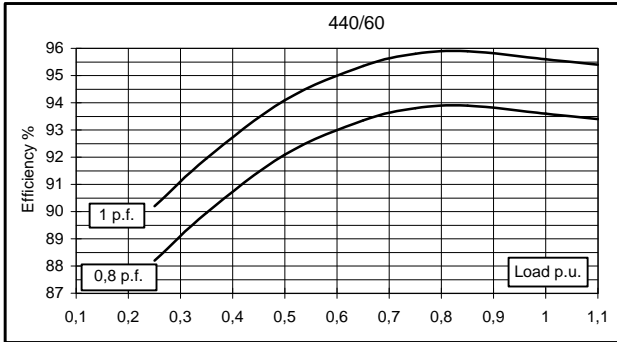
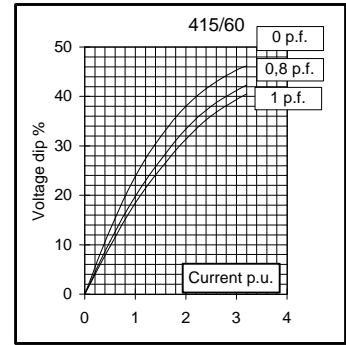
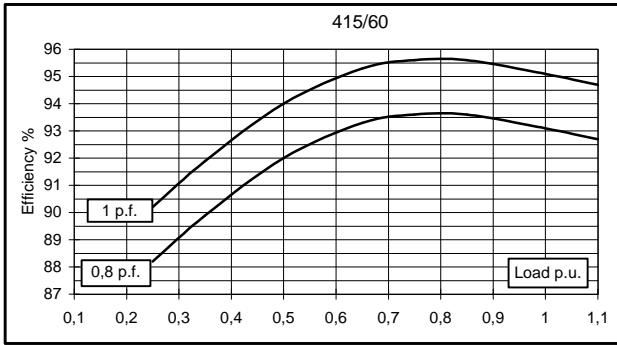

TWO BEARING MOMENTS OF INERTIA

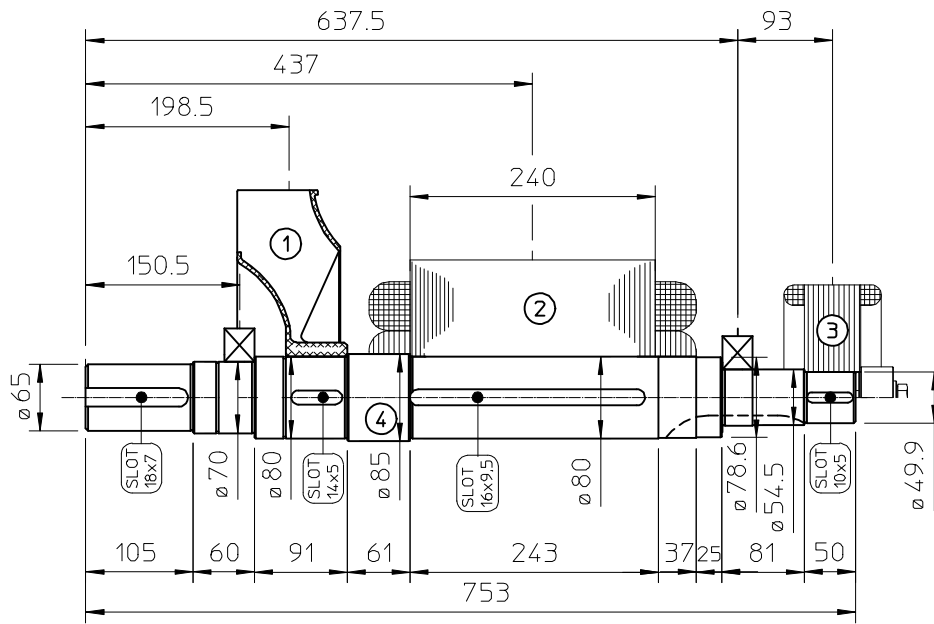

COMPONENT	WEIGHT kg	J kgm ²
1 FAN	3,3	0,0451
2 MAIN ROTOR	81	0,7896
3 EX. ROTOR	14,5	0,0874
4 SHAFT	24,5	0,0184
TOTAL	123,3	0,9405

TWO BEARING DIMENSIONS

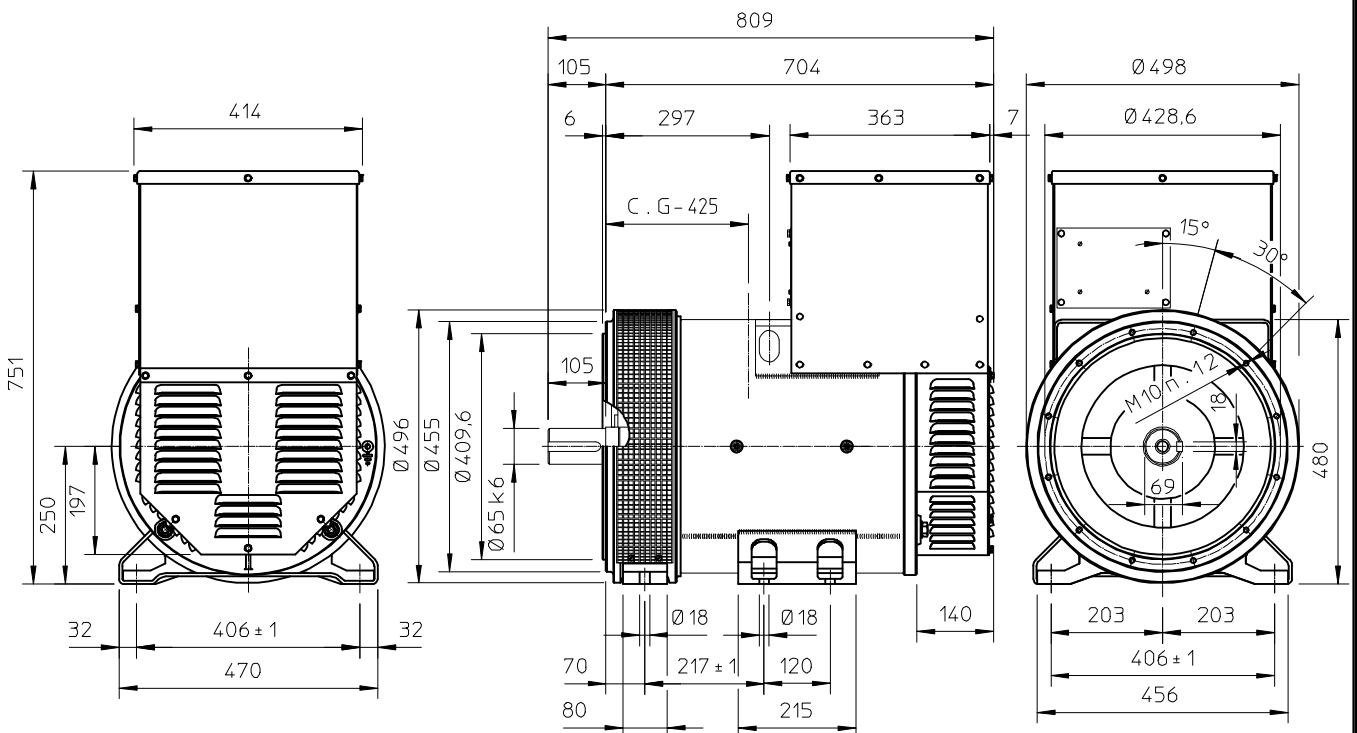

C.G. = GRAVITY CENTER

SINGLE BEARING MOMENTS OF INERTIA

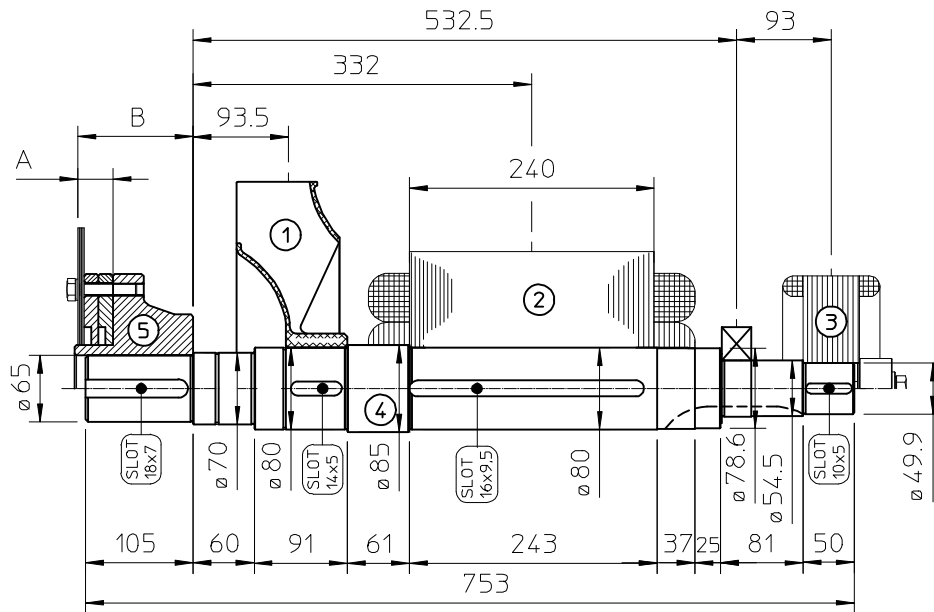

COMPONENT	WEIGHT kg	J kgm ²
1 FAN	3,3	0,0451
2 MAIN ROTOR	81	0,7896
3 EX. ROTOR	14,5	0,0874
4 SHAFT	24,5	0,0184
TOTAL	123,3	0,9405

SAE No	SHAFTS COUPLING FLEX PLATE			
	A	B	WEIGHT kg	J kgm ²
10	46,5	112,8	20,5	0,1342
11,5	37,3	98,6	19,3	0,1512
14	27,4	84,4	21,1	0,2752

SINGLE BEARING DIMENSIONS

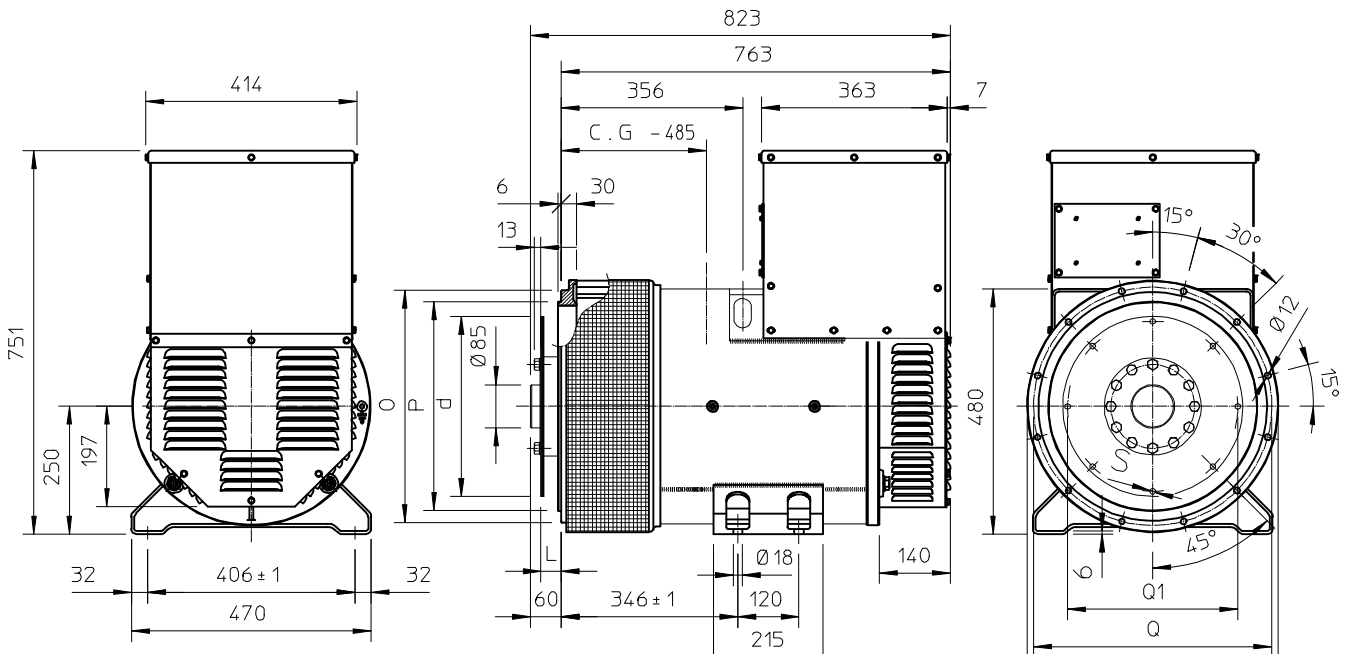

SAE Z.	FLANGIA/FLANGE BRIDE/FLANSCH				SAE Z.	GIUNTI A DISCHI DISC COUPLING DISQUE DE MONOPALIER SCHEIBENKUPPLUNG				
	O	P	Q	N _f f _{ori}		L	d	Q ₁	N _f f _{ori}	S
3	451	409,6	428,6	12	10	53,8	314,32	295,27	8	11
2	489	447,7	466,7	12	11 1/2	39,6	352,42	333,37	8	11
1	552	511,2	530,2	12	14	25,4	466,72	438,15	8	14

C.G. = GRAVITY CENTER