

ﺋﯩﺮﺍﺗﻮﺭ : *StamFord Power*

ﻣﻮﺗﻮﺭ ﺩﯨﺰﯨﻞ : *Chummins-China*

Standby		Prime		ﺩﯨﺰﯨﻞ ﺋﯩﺮﺍﺗﻮﺭ
KVA	KW	KVA	KW	
220	-	200	160	

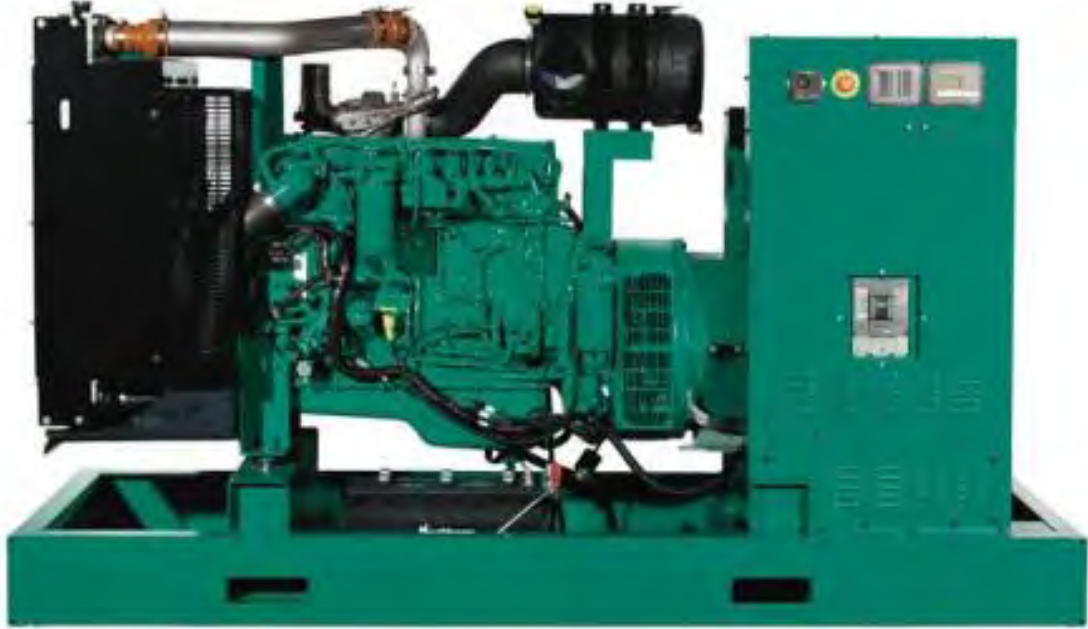

CUMMINS ENGINE DATASHEET



ENGINE MODEL: 6CTAA8.3-G2

PERFORMANCE CURVE: FR92110

VERSION 01 2006/06

	DONGFENG CUMMINS ENGINE Co., Ltd. XiangFan HuBei P.R.CHINA ENGINE DATASHEET—for G-drive		ENGINE MODEL 6CTAA8.3-G2		PERFORMANCE CURVE FR92110
			ENGINE FAMILY D41	CPL 1783	2006/06
Displacement	8.3 L	Air intake way	Air-air after-cooled, turbo-charged		
Cylinder bore	114 mm	Cylinder quantity	6	kW(BHP)	@RPM
Stroke	135 mm			183(245)	1500
Fuel system	P7100 pump _ GAC governor / BYC ASIMCO			Speed-droop	5%
Engine testing with fuel system, water pump and oil pump, without air compressor, alternator, fan, other options and driving accessory. Testing condition: air intake resistance 250 mmHg, exhaust back pressure 50 mmHg.					

Engine Speed-RPM	Standby Power		Base Output Power		Continuous Power	
	kW	HP	kW	HP	kW	HP
1500	203	272	183	245	149	200

	Output Power		Fuel consumption	
	%	kW	HP	g/kW.h
Standby Power				
100	203	272	209	51.4
Base Output Power				
100	183	245	205	45.4
75	137	184	206	34
50	91	123	211	23.3
25	46	61	241	13.5
Continuous Power				
100	149	200	205	37

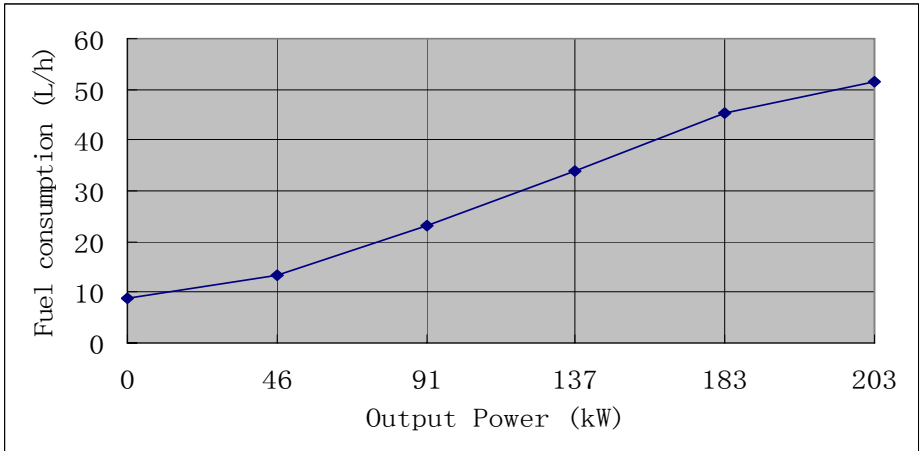

	DONGFENG CUMMINS ENGINE Co., Ltd. XiangFan HuBei P.R.CHINA ENGINE DATASHEET—for G-drive	ENGINE MODEL 6CTAA8.3-G2		PERFORMANCE CURVE FR92110
		ENGINE FAMILY D41	CPL 1783	2006/06

Typical engine data

Net weight	kg	684
Rotate part instantaneous inertia _ without flywheel	kg.m ²	0.37
Distance between gravity center and rear surface of cylinder block	mm	541
Distance between gravity center and center line above of crankshaft	mm	163

Engine installation

Static bent torque permitted—rear surface of cylinder block	Nm	1356
Static bent torque permitted—front surface of cylinder block	Nm	495
Static bent torque permitted—flank surface of flywheel-house	Nm	250

Exhaust system

Max. back pressure	mmHg	76
Diameter of exhaust pipe recommended	mm	100

Air intake system

Max. air intake resistance		
Dirty filter	mmH ₂ O	635
Normal air cleaner and clean filter	mmH ₂ O	254
Heavy duty cleaner and clean filter	mmH ₂ O	381
Diameter of intake pipe recommended	mm	125

Lubrication system

Normal oil pressure range		
Low idle	kPa	207

Rated speed	kPa	276_414
Max. oil temperature permitted in oil pan	°C	121
Oil pan capacity (Max _ Min)	L	18.9_15.1
Lubrication system Min. capacity (oil pan + oil filter)	L	23.8
Usage inclining degree permitted (any direction)	°	45

Fuel system

Fuel injection pump model	BYC P7100 pump with GAC governor	
Max. fuel input resistance of transfer pump	mmHg	102
Max. overflow fuel resistance at overflow pipe of injector	mmHg	254
Total fuel overflow amount	L/h	208

Cooling system

Coolant capacity-engine only	L	12.3
Max. coolant cycling resistance exterior engine	kPa	28
Thermostat adjusting temperature (range)	°C	83_95
Min. opening pressure of radiator cap	kPa	69
Max. coolant temperature permitted _ Standby Power/Base output Power	°C	104/100

Electric system

Starter	12V	24V
Battery charging system	63A	40A
Max. starting circuit resistance	0.00075Ω	0.002Ω
Min. battery capacity_ -12°C (CCA: Cold Cranking Ampere)	950CCA	475CCA

Technical data _ under standard fuel delivery rate FR92110

	Base output Power	Standby Power
Engine speed _ RPM	1500	1500
Output Power _ kW	183	203

Torque _ Nm	1758	1950
Low idle _ RPM	700-950	700-950
Friction energy output _ kW	17	17
Piston speed _ m/s	6.8	6.8
Engine coolant flow _ L/sec	3.3	3.3
Air intake flow _ L/sec	180	187
Exhaust flow _ L/sec	442	485
Exhaust temperature _ °C	500	545
Environment energy output _ kW	N/A	N/A
Coolant energy output _ kW	83	95
Fuel energy output _ kW	N/A	N/A

All data's error within $\pm 5\%$.

Excuse for none notice anymore in case of data changed

DONGFENG CUMMINS ENGINE Co., Ltd.

单轴承 SINGLE BEARING

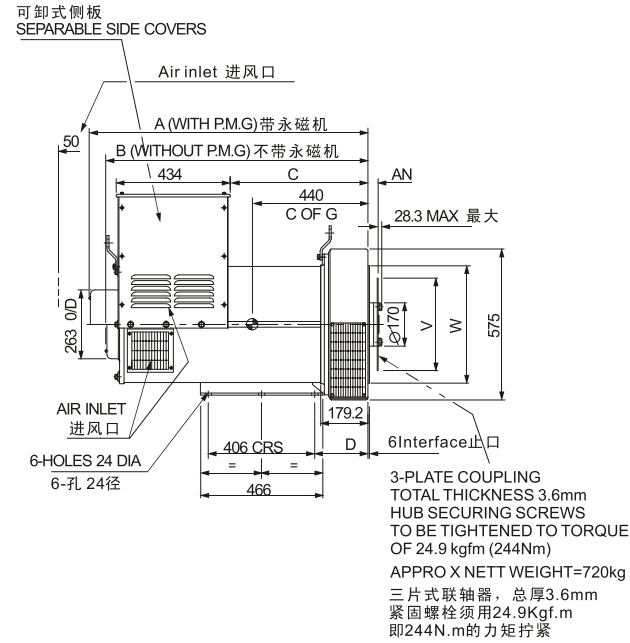

双轴承 DOUBLE BEARING

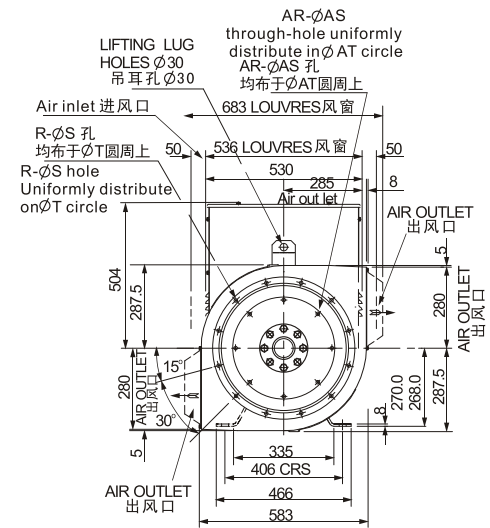
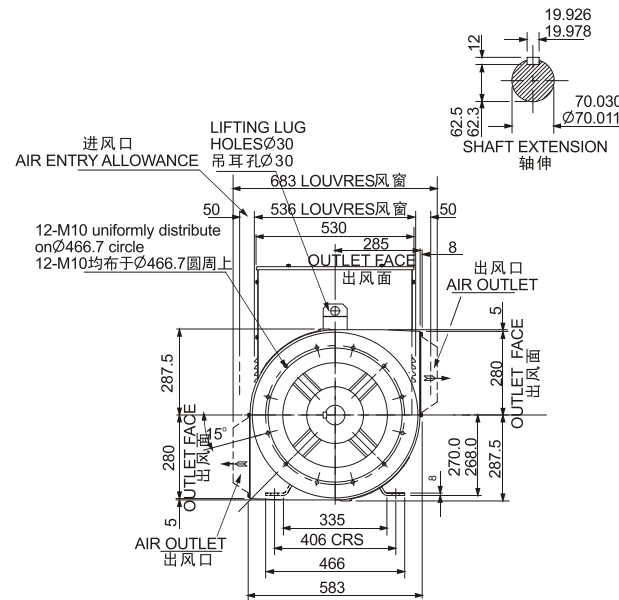
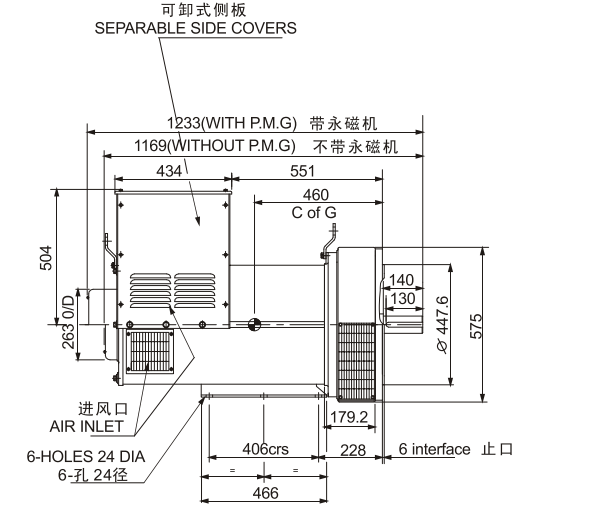

FLANGE 法兰式过渡接套 (mm)

S.A.E.NO.	A	B	C	D	R	S	T	W
1	1063	1000	525	202	12	12.7	530.2	511.1
2	1063	1000	525	202	12	11	466.7	447.6
3	1086.5	1023.5	548.5	225.5	12	11	428.6	409.5

DISC COUPLING 盘片式联轴器 (mm)

S.A.E.NO.	AN	AR	AS	AT	V
11.5	39.68	8	11	333.3	352.3
14	25.40	8	13.5	438.2	466.6

SAE NO SELECTOR CHOWT 驱动片和过渡法兰配套表

	SAE10	SAE11.5	SAE14
SAE 1		•	•
SAE 2		•	
SAE 3	•	•	

NEW ERA SLG

系列三相无刷同步发电机
SERIES THREE-PHASE BRUSHLESS SYNCHRONOUS ALTERNATOR



SLG274 TECHNICAL DATA SHEET

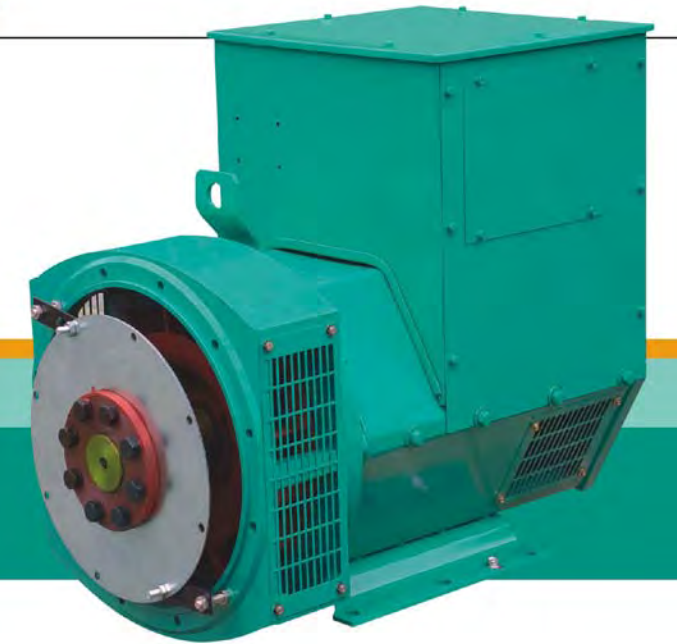

50Hz CLASS "H"

RATINGS	绕组形式 311 / 功率因数0.8 Winding 311 / 0.8 Power Factor													
	持续/125k/40°C Cont./125K/40°C				持续/125k/40°C Cont./125K/40°C				持续/125k/40°C Cont./125K/40°C					
定额/温升/环境温度 Duty / Temp Rise / Ambient T°	三相 3 PHASE								单相 1 PHASE					
相数 PHASE	三相 3 PHASE								单相 1 PHASE					
星形串联 SERIES STAR	380	400	415											
星形并联 PARALLEL STAR	190	200	208											
三角形串联 SERIES DELTA	220	230	240											
双三角形并联 DOUBLE DELTA								220	230	240				
	KVA	KW	KVA	KW	KVA	KW	KVA	KW	KVA	KW	KVA	KW	KVA	KW
SLG274C	100	80	100	80	100	80	60	48	60	48	60	48	60	48
SLG274D	114	91.2	120	96	114	91.2	68	54.4	68	54.4	68	54.4	68	54.4
SLG274E	140	112	140	112	140	112	85	68	85	68	85	68	85	68
SLG274F	160	128	160	128	160	128	96	76.8	96	76.8	96	76.8	96	76.8
SLG274G	180	144	180	144	180	144	108	86.4	108	86.4	108	86.4	108	86.4
SLG274H	200	160	200	160	200	160	120	96	120	96	120	96	120	96
SLG274J	230	184	230	184	230	184	138	110.4	138	110.4	138	110.4	138	110.4
SLG274K	250	200	250	200	250	200	150	120	150	120	150	120	150	120

60Hz CLASS "H"

RATINGS	绕组形式 311 / 功率因数0.8 Winding 311 / 0.8 Power Factor													
	持续/125k/40°C Cont./125K/40°C				持续/125k/40°C Cont./125K/40°C				持续/125k/40°C Cont./125K/40°C					
定额/温升/环境温度 Duty / Temp Rise / Ambient T°	三相 3 PHASE								单相 1 PHASE					
相数 PHASE	三相 3 PHASE								单相 1 PHASE					
星形串联 SERIES STAR	416	440	460	480										
星形并联 PARALLEL STAR	208	220	230	240										
三角形串联 SERIES DELTA	240	254	266	277										
双三角形并联 DOUBLE DELTA								220	230	240				
	KVA	KW	KVA	KW	KVA	KW	KVA	KW	KVA	KW	KVA	KW	KVA	KW
SLG274C	112.5	90	117.5	94	117.5	94	125	100	61.3	49	64.4	51.5	67.5	54
SLG274D	131.3	105	137.5	110	137.5	110	146.3	117	72	57.6	75	60	78.8	63
SLG274E	160	128	167.5	134	167.5	134	178.8	143	84	67.2	90	72	96	76.8
SLG274F	181.3	145	190	152	190	152	206.3	165	97.5	78	103.1	82.5	108.8	87
SLG274G	205	164.5	218.5	174.8	218.5	174.8	231.4	185.1	110.5	88.4	115.7	92.6	123.4	98.7
SLG274H	237.5	190	245	196	245	196	255	204	127.5	102	135	108	142.5	114
SLG274J	296	215.2	281	224.8	294	215.2	300	240	150	120	157	125.6	161	128.8
SLG274K	291	232.8	299	239.2	235.2	250	312.5	250	155	124	166	132.8	175	140

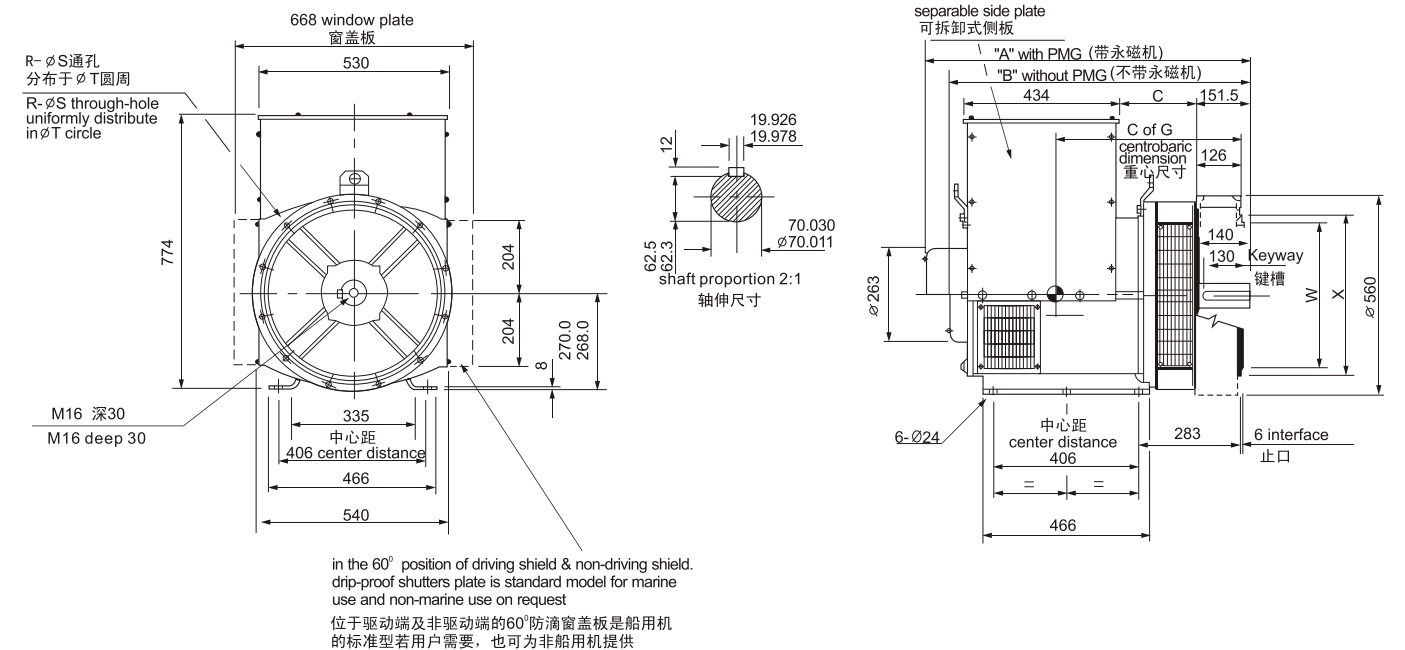
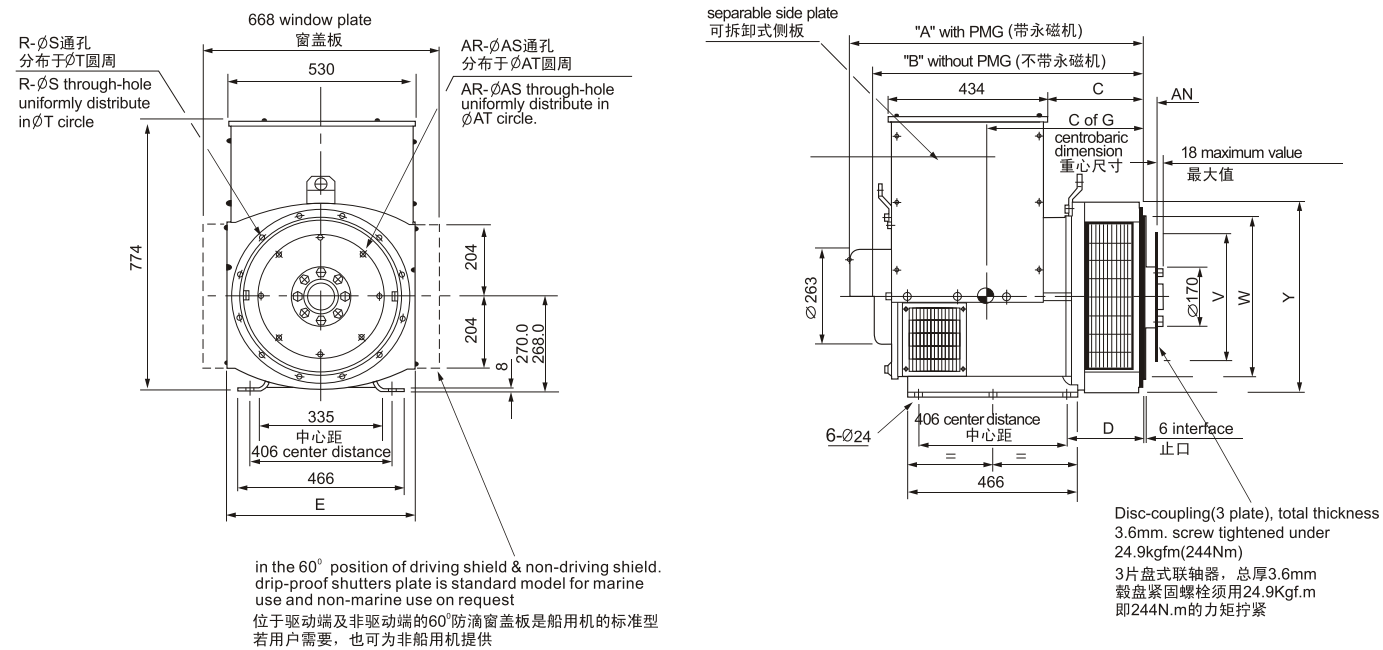

DIMENSION 尺寸(mm)									
	型号 Model	A	B	C	E	C of G	N.W(kg)	G.W(kg)	LXWXH(mm)
SAE1	SLG274C	813.3	750.3	274.3	554	365	385	415	900X650X975
	SLG274D	813.3	750.3	274.3	554	375	405	435	900X650X975
	SLG274E	928.3	865.3	389.3	554	390	455	485	1020X650X975
	SLG274F	928.3	865.3	389.3	554	415	500	530	1020X650X975
	SLG274G	978.3	915.3	439.3	554	435	550	580	1080X650X975
	SLG274H	1018.3	955.3	479.3	554	455	600	630	1110X650X975
SAE2&3	SLG274C	799	736	260	544	398	385	415	900X650X975
	SLG274D	799	736	260	544	422	405	435	900X650X975
	SLG274E	914	851	375	544	489	455	485	1020X650X975
	SLG274F	914	851	375	544	527	500	530	1020X650X975
	SLG274G	964	904	425	544	579	550	580	1080X650X975
SLG274H	1004	941	465	544	625	600	630	1110X650X975	

FLANGE 法兰式过渡接套 (mm)							
S.A.E.NO.	D	R	S	T	W	X	Y
1	216.3	12	12.7	530.2	511.1	553	580
2	202	12	11	466.7	447.6	490	530
3	202	12	11	428.6	409.5	451	530

DISC COUPLING 盘片式联轴器 (mm)					
S.A.E.NO.	AN	AR	AS	AT	V
10	53.98	8	11	295.3	314.2
11.5	39.68	8	11	333.3	352.3
14	25.40	8	13.5	438.2	466.6

DIMENSION 尺寸(mm)				
型号 Model	A	B	C	C of G
SLG274C	905	842	215	420
SLG274D	905	842	215	430
SLG274E	1020	957	330	445
SLG274F	1020	957	330	475
SLG274G	1070	1007	380	490
SLG274H	1110	1047	420	510

FLANGE 法兰式过渡接套 (mm)					
S.A.E.NO.	R	S	T	W	X
1	12	12.7	530.2	511.1	553
2	12	11	466.7	447.6	495
3	12	11	428.6	409.5	451

TRANSPORTATION DATA 运输数据			
型号 Model	N.W(kg)	G.W(kg)	LXWXH(mm)
SLG274C	395	435	980X650X975
SLG274D	420	460	980X650X975
SLG274E	470	510	1080X650X975
SLG274F	510	550	1080X650X975
SLG274G	560	600	1110X650X975
SLG274H	610	650	1160X650X980